



Lowara UK Variable Speed Booster Sets

Your trusted partner

The professionals in pump technology across all building services

Lowara is a leading supplier of pump technology to the building services industry. Thousands of commercial and residential applications rely on our pumps, day in day out.

Lowara is globally recognised for its quality in pumping products and services, from consultation to implementation.

This brochure will give you an overview of our specialised Variable Speed Booster Set pumps range.

Please contact us for detailed technical specifications and quality standards.

Find out more on www.lowara.co.uk

CONTENTS	PAGE
Booster set introduction	5
Booster Set main characteristics	7
Selecting a Booster Set	8
Assessment of probable demand	9
Assessing head requirement	10
Electrical Data and Noise emissions Levels	11
GTKS Series Booster Set	12
GHV10 - GHV40 Series Booster Set	29
Resvari Variable Speed Booster Set	81
Mini VH and VV Variable Speed Booster Set	84

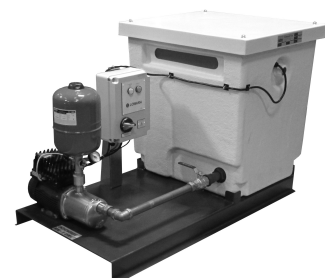
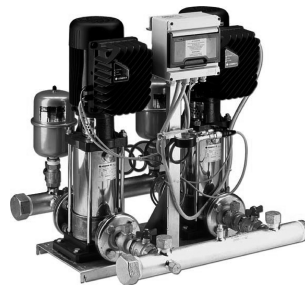
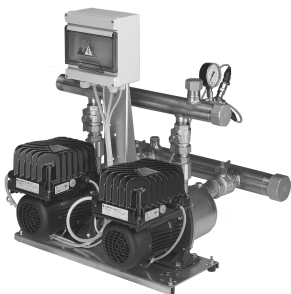



a xylem brand

VARIABLE SPEED BOOSTER SETS

Wide range of 1, 2, 3 and 4 pump variable speed booster sets with individual transducers for each pump giving a very robust operating system.

APPLICATIONS

- Water supply to domestic dwelling and office buildings, hotels, shopping centers, factories, and greenhouses.
- Water supply for agricultural use (irrigation systems).
- Water supply to systems requiring constant pressure.

INTRODUCTION

Lowara booster sets have been designed to be both compact and cost effective. Both the TKS and Hydrovar range are built to exacting standards and as such are suitable for the harshest environments. Packaged sets are suitable to cover all building service applications from small domestic premises to large building complexes as well as Irrigation.

RELIABLE CONTROLS

The control system in any booster set must be robust. The environment in which they operate can often be subject to power fluctuations, induced spikes, RFI and EMI. Both the TKS and Hydrovar uses proven electronics to reduce exposure from all conditions normally encountered in their operating environment and will also ensure long periods of operation with minimal down time. This product has been fully tested and complies with the latest EC directives for EMC emissions and immunity, and the low voltage and machinery directives.

PUMP CONFIGURATION

Hydrovar sets can be supplied in many configurations.

Single pump, full duty operation.

Two pumps arranged as duty assist or duty standby.

Three pumps arranged as duty-assist-assist or standby.

Four pumps arranged as duty-assist-assist-assist or standby.

TKS sets can be supplied as single or twin pump sets arranged for duty only, duty/assist or duty standby.

GTKS END SUCTION



GTKS MULTISTAGE



GHV20



GHV30



INSTALLATION AND SERVICE

Each set comes fully packaged complete with isolating valves, non return valves (Anti-vibration feet), and pressures sensors.

Small sets are provided with screwed manifolds whilst all other sets are provided with flanged manifolds.

Pressure vessels are normally supplied separate from the base to keep the pump set size to a minimum for ease of shipping and manoeuvrability, however vessels can be integrated into the pump set when required. All pumps can easily be removed for servicing.

PUMPS

Lowara have been manufacturing a large range of high quality end suction and vertical multistage pumps for many years. Booster set manufacturers have been quick to see the benefits of this range and many have incorporated them into their own booster set designs.

The Lowara range of booster sets have been designed and built to the same exacting standards as the pump range, this combination of building both pump and set results in an extremely reliable and cost effective solution to cold water boosting.

BOOSTER SET SELECTION

In the majority of applications the booster set must be capable of providing the maximum probable simultaneous demand. As this demand is not normally continuous, the duty can be shared between several pumps.

Where the flow rate is relatively small a two pump set can have each pump sized to cater for 100% of the duty, one pump acting as duty and one pump acting as standby.

As an alternative arrangement each pump can be sized to 60% of maximum demand. One pump acting as duty which will operate most of the time. The second pump will operate to assist the duty pump in peak demand periods, giving more than adequate support.

On systems with higher flow rates it may be more economical to split the duty between three pumps. Each pump can be sized to 50% of maximum demand.

SPECIAL REQUIREMENTS

All booster sets can be easily adapted to meet most customer specific requirements. If you have a special requirement please contact our head office who will be pleased to offer technical advice and design a system tailored to your specific requirement.

GHV40



Resvari



Mini VH version



Mini VV version



MAIN CHARACTERISTICS OF ELECTRIC PUMPS USED IN GTKS AND GHV BOOSTER SETS

CEA, CEAM, CA, CAM

Close-coupled, threaded centrifugal electric pumps, single impeller (CEA) and twin-impeller type (CA). Stainless steel pump body, seal housing, impeller and diffuser. Continuous duty, enclosed IE2 motor with external ventilation and finned casing made of aluminium alloy.

HM

Multi-stage centrifugal horizontal electric pumps with power up to 0.9 kW. Stainless steel pump body, seal housing and diffuser. Impellers made of technopolymer. Continuous duty, enclosed IE2 motor with external ventilation and finned casing made of aluminium alloy.

e-SV

Multi-stage centrifugal vertical electric pumps with high power efficiency up to 22 kW. Stainless steel pump body, seal housing, diffuser and impellers. Continuous duty, enclosed standard IE2 motor with external ventilation and finned casing made of aluminium alloy.



SELECTING A SET

The first thing to do when selecting a set is to determine the volume of water required and the pressure it must produce.

CALCULATING THE FLOW RATE

- The volume of water called **water requirement** depends on the type of users, e.g. homes, offices, schools, as well as their number. The theoretical requirement is the total volume of water required by all the users. In actual fact, since it is very unlikely that there should be a simultaneous demand by all the users, the **real requirement** is lower than the theoretic one.

CALCULATING THE HEAD

- The pressure required depends on the type of user. A number of factors must be taken into account, including the **height of the building**, the suction conditions and the flow resistance in the pipes.

SELECTING A BOOSTER SET

- According to the required flow rate and head values, it is possible to identify the most suitable type of electric pump. Single pump booster sets are normally only selected on systems that do not have a critical demand, I.E where an alternative supply is available. On two-pump sets the pumps normally **act as back-up for one another**. A single pump is normally sufficient to provide for average requirements, while in conditions of high demand the back up pump may be called in to assist. With the **cyclic changeover** function duty assignment is rotated to ensure both pumps remain active and with even running hours, so wear is uniform and the use factor is reduced for longer pump life. This system also ensures **continuity of operation** in case one of the pumps needs maintenance.

VESSELS

- Lowara have included an 8lt vessels with all Teknospeed sets and a 24lt vessel for each pump on all other sets normally fitted on the discharge pipe in front of each pump giving a more compact design.

ASSESSMENT OF PROBABLE DEMAND

The method adopted is based on loading unit values as detailed in the Plumbing Engineering Design Guide published by the Institute of Plumbing.

When designing a hot or cold water supply system an assessment must be made to obtain the maximum probable simultaneous demand.

Depending on the type of services being provided it rarely occurs for all the appliances to be used at the same time therefore the design usually allows for a peak usage which is less than the maximum.

Probable demand will depend on, the type of building and its use, type of appliances installed and frequency of use.

The simultaneous demand in most installations can be calculated with an adequate degree of accuracy using the loading unit concept.

The usage patterns and types of appliances in different installations will vary greatly.

Sports and Leisure centres for example are usually calculated directly by the flow rates of each appliance, without diversity factors. Each case will need to be looked at in its own right and assessed accordingly. Judgement of the designer must prevail.

Loading unit values vary for each type of appliance. A loading unit has no precise value in terms of litres per second.

See loading unit table below.

By multiplying the total number of each appliance by the appropriate loading unit number and adding the resultant totals together, the recommended flow can be read from chart.

Loading unit table

APPLIANCE	Loading Unit	Recommended Flow L/s
WC	1,5	0,12
Wash basin (hot & cold)	3	0,3
Sink (hot & cold)	6	0,4
Bath (hot & cold)	20	0,6
Shower (hot & cold)	10	0,24
Washing machine	2	0,3

Working Example

A block of standard flats containing a total of 70 dwellings

Each standard flat is assumed to have:

1 x Hand basin hot & cold = 3 L/U x 70 = 210

1 x WC cold only = 1.5 L/U x 70 = 105

1 x Shower hot & cold = 10 L/U x 70 = 700

1 x Sink hot & cold = 6 L/U x 70 = 420

Total Loading Unit = 1435

This figure can now be read from chart opposite:

total flow = 8.5 L/s

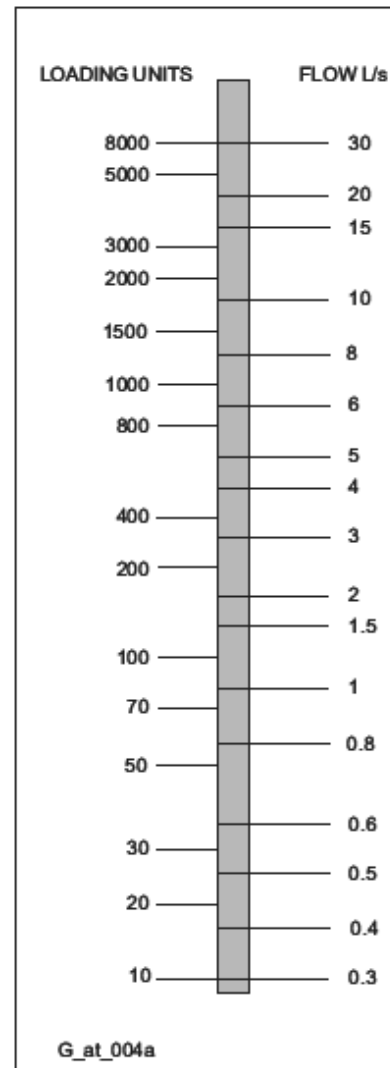

ASSESSING HEAD REQUIREMENT

The **head** required in a boosted cold water system consists of three components, static head, residual pressure and system friction losses. The values of these three components are added together to give the total required head at the system flow rate.

Static head (He): This is the difference between the break tank low water line and the highest discharge point in the building. If the height of the build is not known, then 2.8-3.0 metres per floor can be used to assess the building height.

Residual pressure (Hr): This is the pressure required at the highest outlet device, normally 20 metres.
Note: Some modern showers may require higher pressures.

System friction losses (Hc): The total losses through pipework, pipework fittings, valves, PRV's and all other equipment fed through the pumpset must be added to find the total system losses.

On conventional systems that do not include excessive runs of pipe or specialised components a rough guide would be to allow 0.05 metres friction loss for each metre of static head.

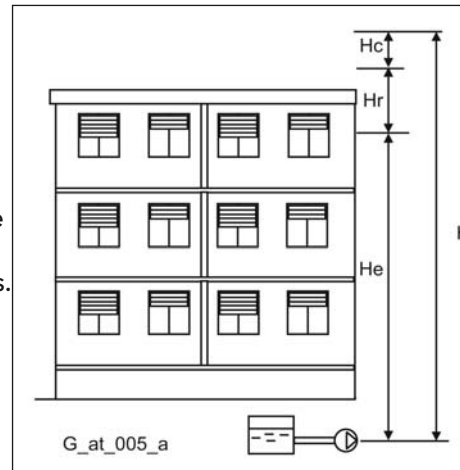

Example:

Static head (He): Building height four floors @ 2.8m each	= 11.2m +
Residual pressure (Hr): Pressure at highest outlet	= 20m +
Friction losses (Hc): 11.2 (static head) x 0.05	= 0.56m
Total pump head required (H)	= 31.76m (3.11 Bar)

Pressure limitations

The designer must ensure that adequate precautions are taken to ensure that the system is capable of withstanding the closed valve head produced by the pump set. In cases where closed valve pressures cannot be tolerated, pressure reducing valves should be fitted down stream of the booster set.

Velocity

Pipework within the system should be sized to limit the velocity to the figures stated in table below. Higher velocities will lead to excessive noise, wear and higher running costs

PIPE SIZE	SUCTION PIPE m/s	DELIVERY PIPE m/s
Less than 80mm	0,46	0,91 to 1,07
100-150mm	0,55	1,22 to 1,52
200mm	0,76	1,68
250 and above	0,91	1,82 to 2,13

BOOSTER SIZING

What information do we require to size a booster set?

- As a minimum we need to know:
 - The total flow rate, or information to assess this.
 - The total head at flow rate, or the height of building.
 - If the pumps are to operate under positive head, or suction lift conditions.
 - Where the set is to be sited, I.E. basement or roof.
 - Preferred choice fixed or variable speed
- Additional information if available:
 - How to split the duty for particular applications I.E. duty/standby or duty/assist.
 - The size and material of the connecting pipework.

GHV/GTKS 10/20/30/40 ELECTRICAL DATA

NOMINAL POWER 1 PUMP	GTKS 10 ABSORBED CURRENT 1 X 230V	GTKS 20 ABSORBED CURRENT 1 X 230V	GHV10../M ABSORBED CURRENT 1 X 230V	GHV20../M ABSORBED CURRENT 1 X 230 V	GHV10 ABSORBED CURRENT 3 X 400V	GHV20 ABSORBED CURRENT 3 X 400V	GHV30 ABSORBED CURRENT 3 X 400V	GHV40 ABSORBED CURRENT 3 X 400V
0.37	2.3	4.6						
0.55	3.5	6.8						
0.75	4.9	9.3	5.3	10.6				
1.1	6.8	13.6	7.5	15	2.36	5	7.4	9.9
1.5			9.9	19.8	2.97	6.7	9.4	12.5
2.2			14.5	29	4.33	9.1	13.6	18.2
3					6.07	12.7	19.1	25.5
4					7.63	16	24	32
5.5					10.4	21.8	32.8	43.7
7.5					14	29.4	44.1	58.8
11					20.3	42.6	63.9	85.3
15					26	54.6	81.9	109.2
18.5					33.2	69.7	104.6	139.4
22					38.6	81.1	121.6	162.1

NOISE EMISSION LEVELS

50 Hz 2900 min -1		LpA (dB +/-2) Electric motor only					
P2 (kW)	IEC	GHV10	GHV20	GHV30	GHV40	GTKS10	GTKS20
0.37	71	< 70	< 70	< 70	< 70	< 70	< 70
0.55	71	< 70	< 70	< 70	< 70	< 70	< 70
0.75	80R	< 70	< 70	< 70	< 70	< 70	< 70
1.1	80	< 70	< 70	< 70	< 70	< 70	< 70
1.5	90	< 70	< 70	< 70	< 70		
2.2	90	< 70	< 70	< 70	< 70		
3	100R	< 70	< 70	< 70	< 70		
4	112R	< 70	< 70	< 70	< 70		
5.5	132R	< 70	< 70	< 70	< 70		
7.5	132	74	74	76	77		
11	160R	76	76	78	79		
15	160	74	74	76	77		
18.5	160	76	76	78	79		
22	160R	73	73	77	78		

R = Reduced motor casing

GTKS SERIES SINGLE AND TWIN BOOSTER SET

Single-phase variable-speed pressure boosters with pressure transducer control. CA, CEA, HM and e-SV versions available.

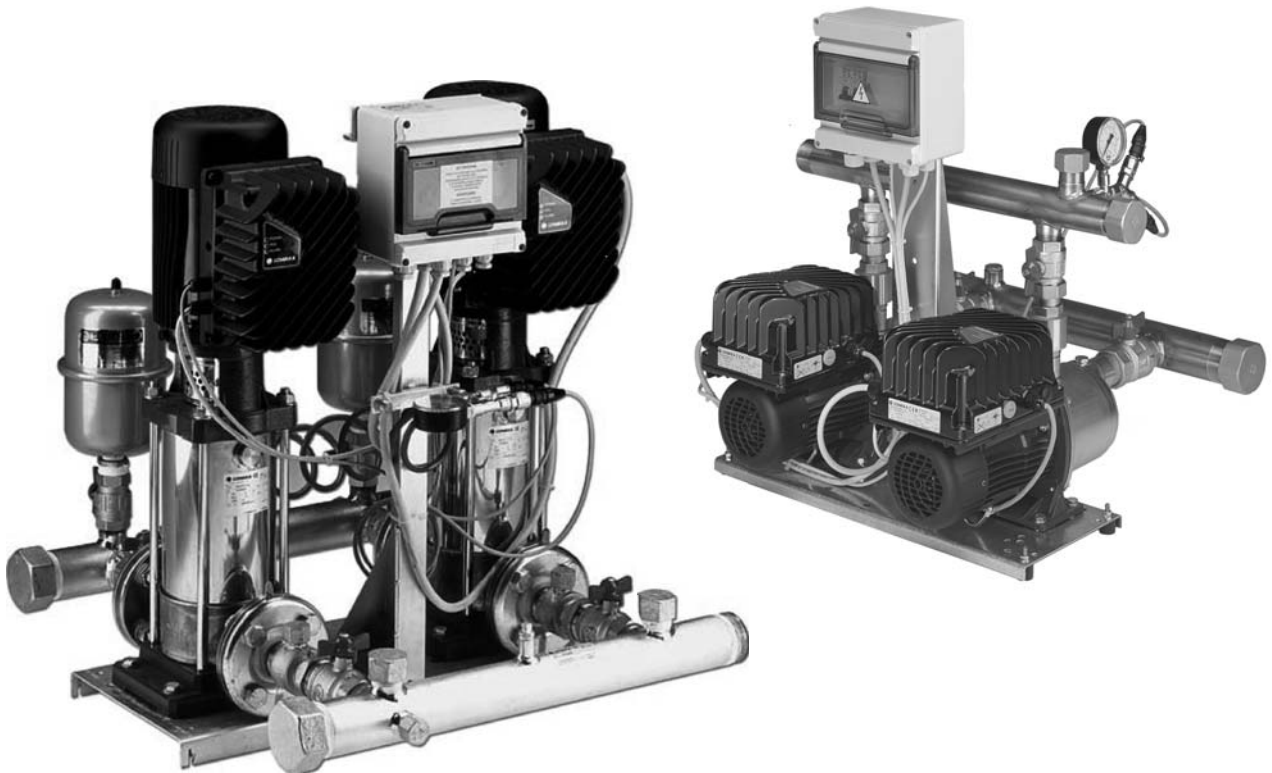
**SPECIFICATIONS**

Number of pumps: 1 or 2

Delivery: up to 16 m³/h

Head: up to 70 m

Electric supply panel voltage:

1 x 230 V 50 Hz (single-phase)

Power: 1 or 2 x 1.1 kW

Motor starting: variable frequency operation

Temperature of pumped liquid:

C SETS: 0°C to +85°C

HM SETS: 0°C to +60°C

SV SETS: 0°C to +80°C

Pump type: horizontal and vertical

MATERIALS

Pump: Stainless steel

Manifolds: AISI 304

Base: Galvanised**

PRODUCT FEATURES

- Easy to install.
- Trouble-free servicing.
- Pressure transducer control (one per pump).
- Compact solution for residential use.
- Constant pressure.
- Protection against dry running.
- Automatic switching.
- Vibration dampers under base*
- Plastic control panel IP55*
- Unit factory assembled, calibrated and tested.
- Each set comes complete with an 8lt vessel for each pump.

Please Note:

* not on single pump units.

** base plates are not provided with single pump end suction sets.

IDENTIFICATION CODES

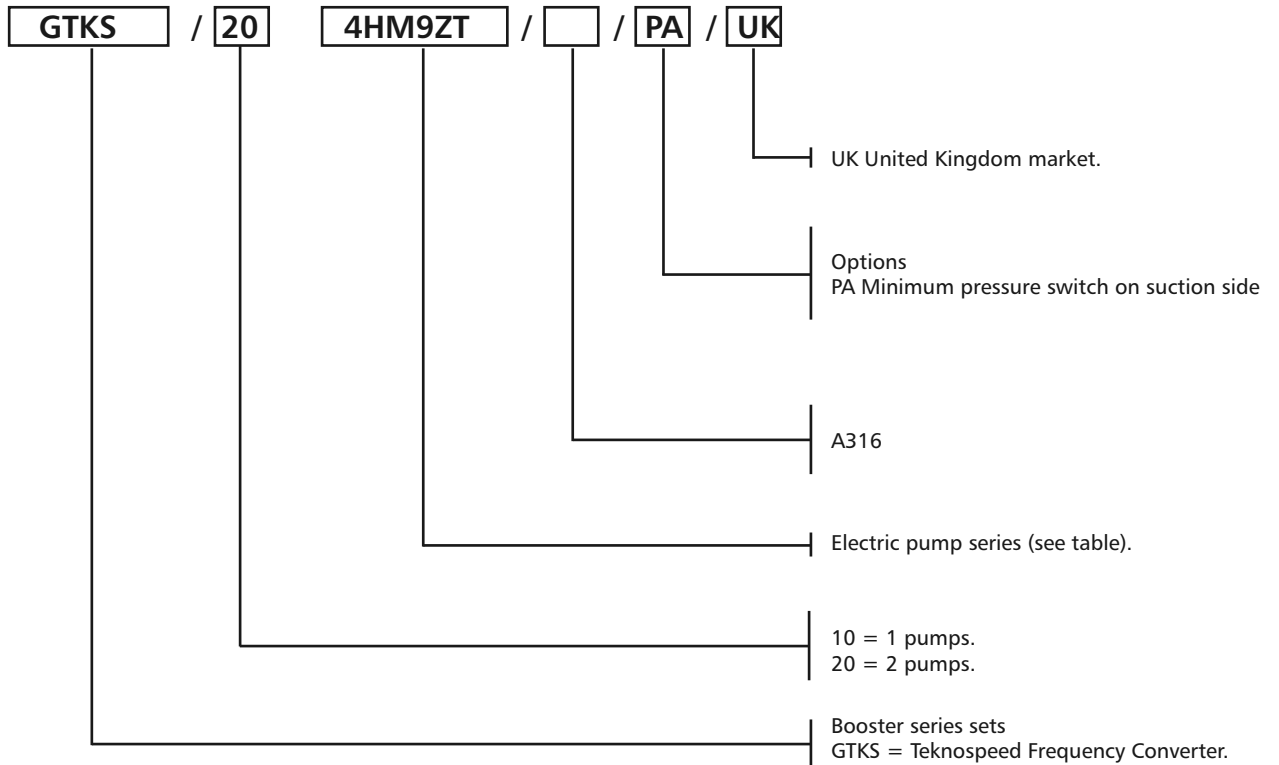

SPECIAL VERSIONS

Special versions featuring different material/operating temperatures and electrical panels with additional functions are available on request.

CONTROL PANEL AND BASIC CONNECTION DETAILS

GTKS10 single phase booster set 1.1Kw

GTKS20 single phase booster set 1.1Kw

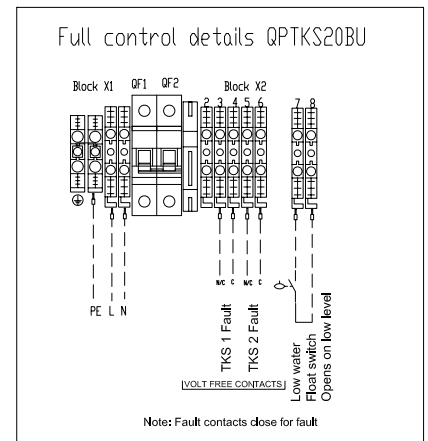
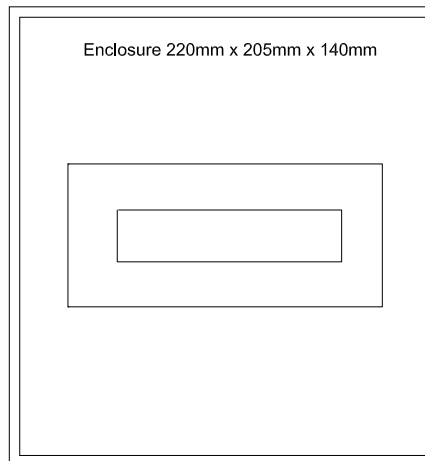
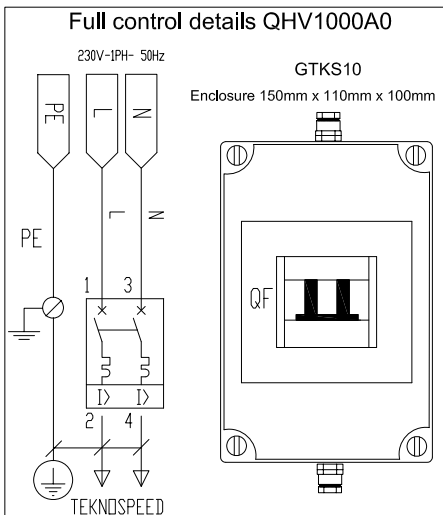

GTKS SERIES
HYDRAULIC SINGLE PUMP PERFORMANCE TABLE AT 50 Hz

Pump Type	Rated Power kW	Q + Delivery									
		l/min 0	20	30	40	50	60	70	80	100	120
		m ³ /h 0	1.2	1.8	2.4	3	3.6	4.2	4.8	6	7.2
H + TOTAL HEAD METRES COLUMN OF WATER											
TKS/2HM3ZT	0.3	22.2	20	18.2	16.1	13.7	10.9	7.9			
TKS/2HM5ZT	0.55	45.5	40	36.3	32.1	27.3	22.1	16.5			
TKS/2HM7ZT	0.75	57	50.8	46.2	40.8	34.6	27.8	20.5			
TKS/4HM4ZT	0.45	23.6			19.3	18.1	16.9	15.6	14.2	11.1	7.6
TKS/4HM5ZT	0.55	35			28.6	26.9	25	23.1	21	16.6	11.5
TKS/4HM9ZT	1.1	58.4			48.3	45.6	42.8	39.8	36.5	29.1	20.3
TKS/4HMS7T	0.75	46.7			38.9	36.8	34.6	32.2	29.6	23.7	16.7

Pump Type	Rated Power kW	Q + Delivery									
		l/min 0	20	30	40	50	60	70	80	100	120
		m ³ /h 0	1.2	1.8	2.4	3	3.6	4.2	4.8	6	7.2
H + TOTAL HEAD METRES COLUMN OF WATER											
TKS/CA 70/33	0.75	42.9	38.8	36.9	31.7	23.9					
TKS/CA 70/44	0.55	45.5	49.5	47.5	42	34					
TKS/CEA 80/5	0.75	32		30	29.3	28	27.4	26	24.7	21	

Pump Type	Rated Power kW	Q + Delivery									
		l/min 0	20	30	40	50	60	70	80	100	120
		m ³ /h 0	1.2	1.8	2.4	3	3.6	4.2	4.8	6	7.2
H + TOTAL HEAD METRES COLUMN OF WATER											
TKS/BG7	0.75	45.4	38.1	34.8	31.7	28.6	25.6				
TKS/BG11	1.1	53.2	45.8	42.5	39.5	36.5	33.5	30.3			

Pump Type	Rated Power kW	Q + Delivery								
		l/min 0	83.3	100	133	170	183.3	233		
		m ³ /h 0	5	6	8	10.2	11	14		
H + TOTAL HEAD METRES COLUMN OF WATER										
TKS/10SV01F007T	0.75	11.8	11.2	10.9	9.9	8.3	7.6	4.3		
TKS/10SV02F007T	0.75	23.6	21.9	21.3	19.6	17	15.8	10		
TKS/10SV03F011T	1.1	35.7	33	32.1	29.6	25.8	24.1	16		

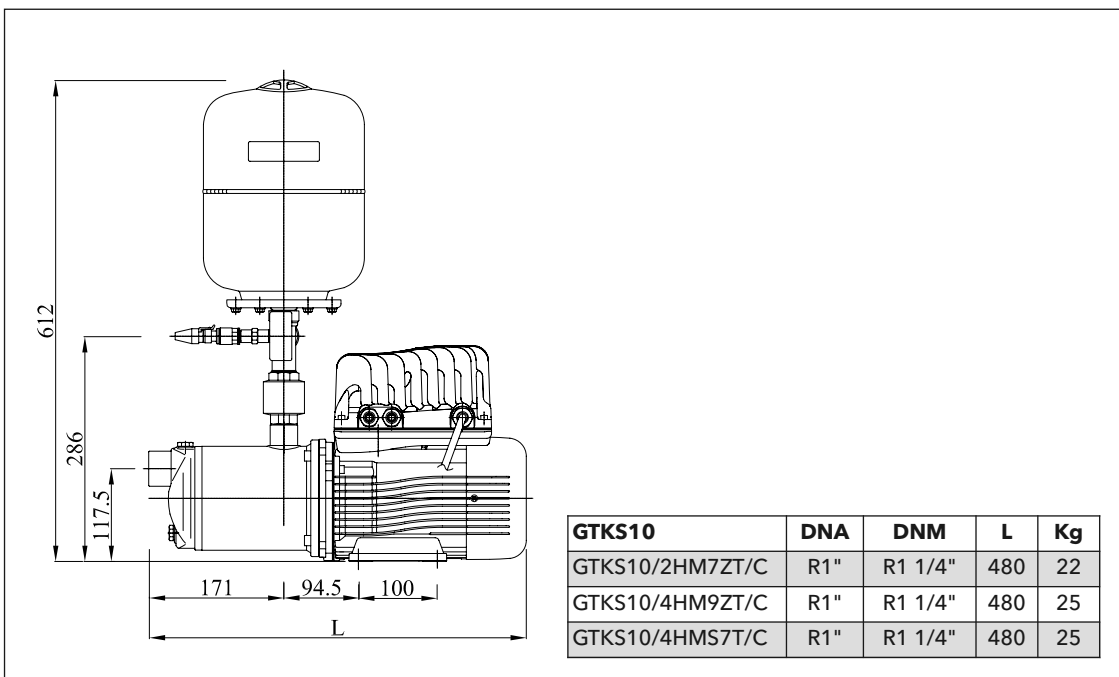
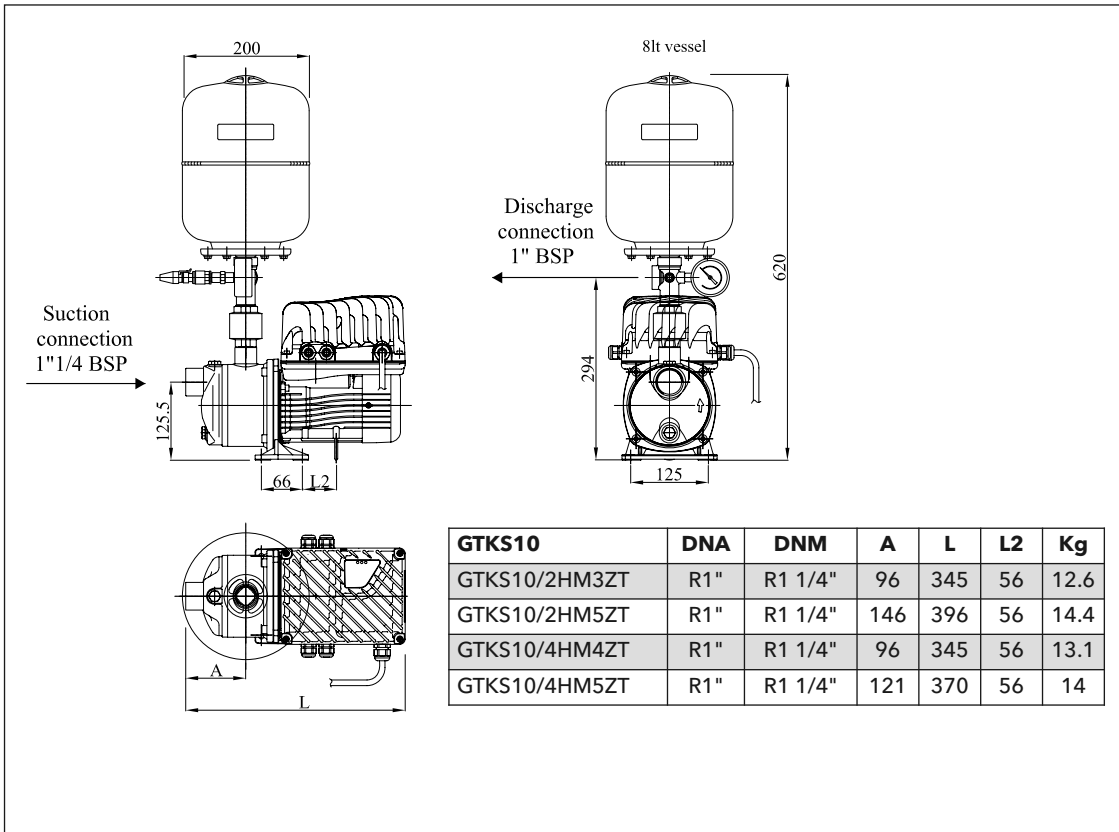
GTKS10 SERIES DIMENSION DETAILS HORIZONTAL PUMPS

GTKS10 SERIES DIMENSION DETAILS HORIZONTAL PUMPS

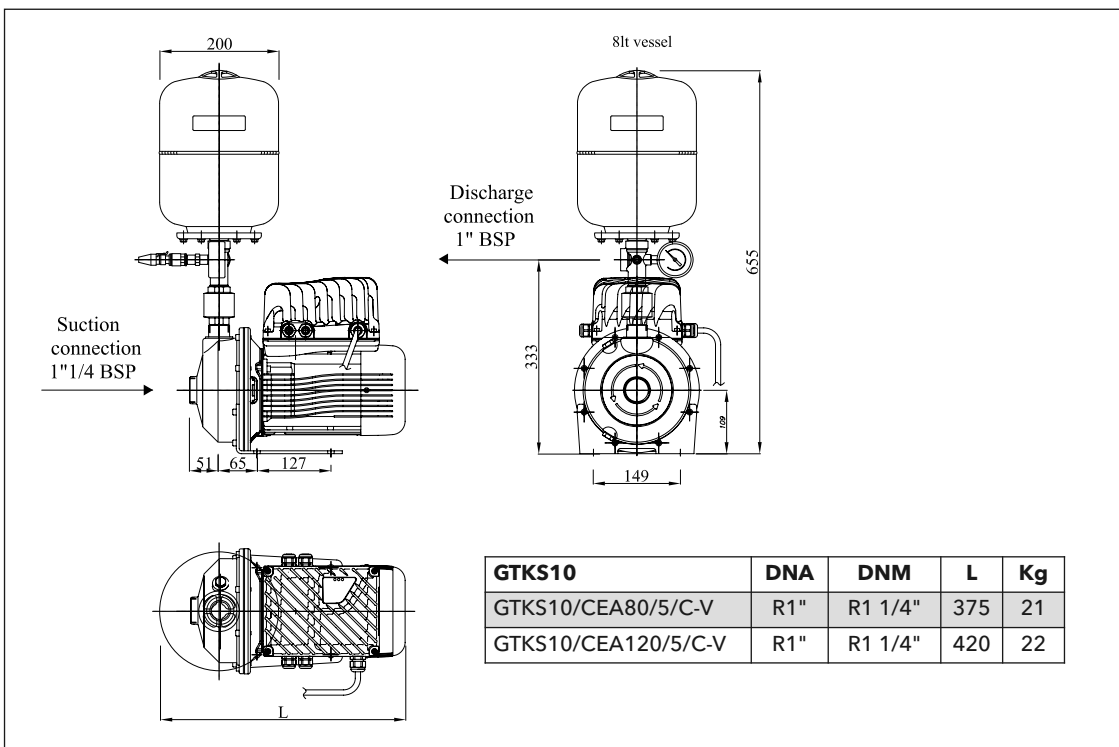
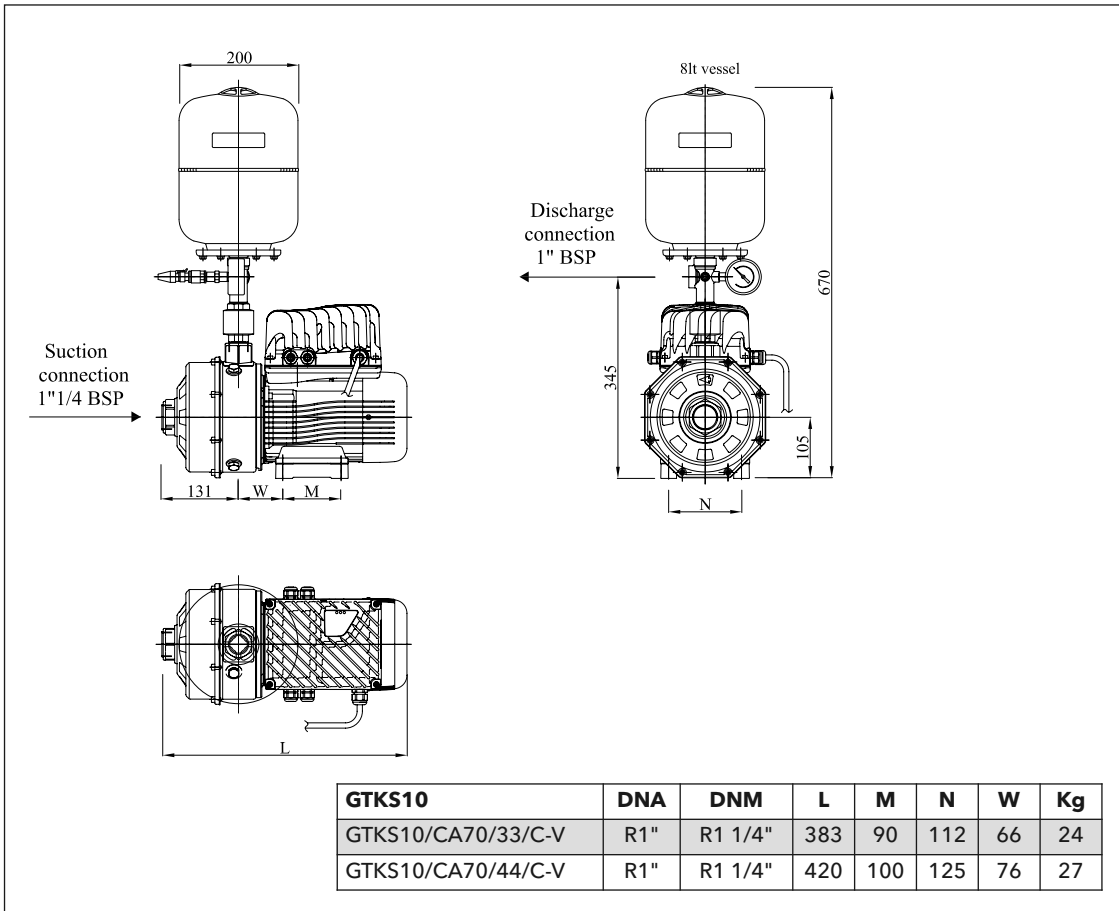

GTKS10 SERIES DIMENSION DETAILS HORIZONTAL PUMPS

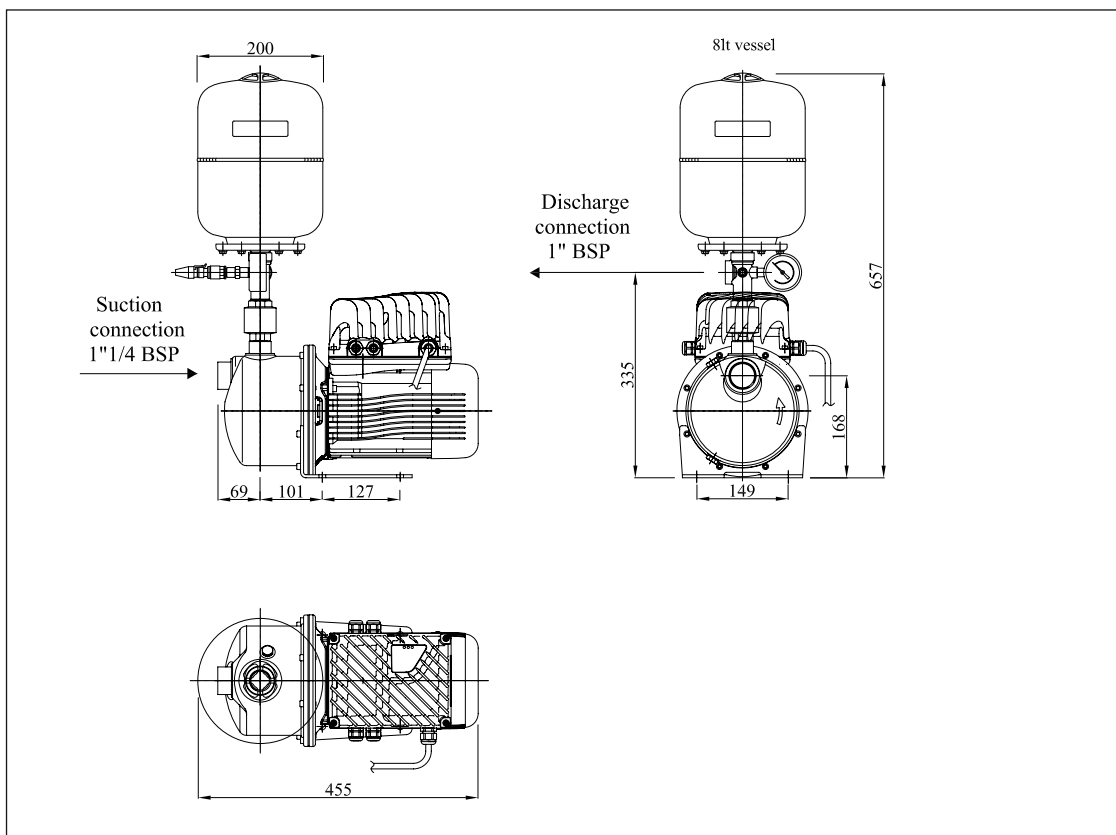

GTKS10	DNA	DNM	Kg
GTKS10/BG7/C	R1"	R1 1/4"	23
GTKS10/BG11/C	R1"	R1 1/4"	24

GTKS10 SERIES DIMENSION DETAILS VERTICAL PUMPS

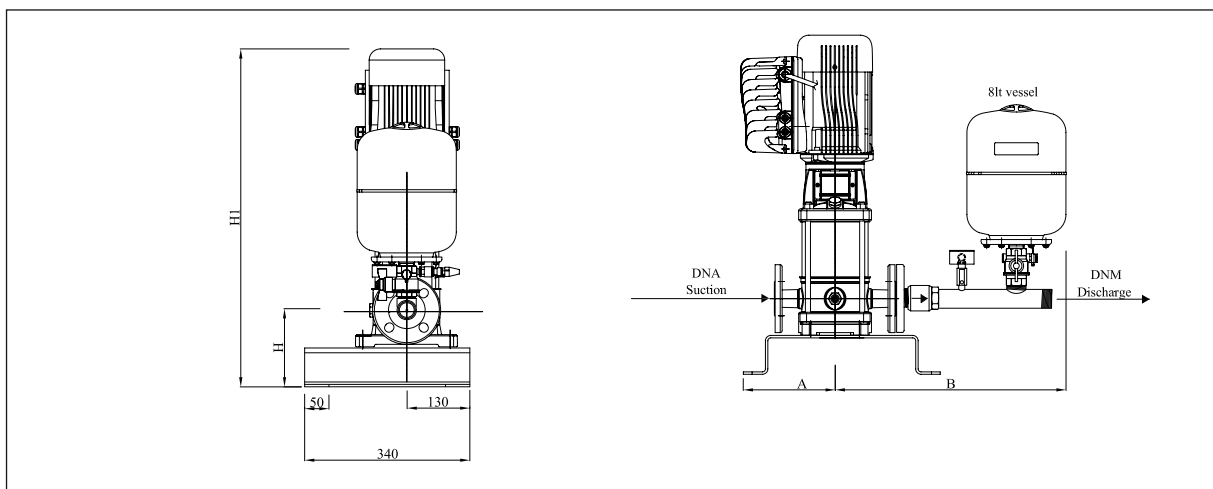

GTKS10	DNA/DNM	A	B	H	H1	L	Kg
1SV02	DN25	175	485	155	567	660	27
1SV03	DN25	175	485	155	567	660	27.4
1SV04	DN25	175	485	155	587	660	27.8
1SV05	DN25	175	485	155	607	660	28.2
1SV06	DN25	175	485	155	627	660	28.6
1SV07	DN25	175	485	155	647	660	28.9
1SV08	DN25	175	485	155	689	660	29.2
1SV09	DN25	175	485	155	709	660	29.6
1SV10	DN25	175	485	155	729	660	30
1SV11	DN25	175	485	155	749	660	30.4
1SV12	DN25	175	485	155	811	660	37.7
1SV13	DN25	175	485	155	831	660	38.1
1SV15	DN25	175	485	155	871	660	39
1SV17	DN25	175	485	155	851	660	47
1SV19	DN25	175	485	155	951	660	49.8
1SV22	DN25	175	485	155	1011	660	51
3SV02	DN25	175	485	155	567	660	26.8
3SV03	DN25	175	485	155	567	660	27.2
3SV04	DN25	175	485	155	587	660	27.6
3SV05	DN25	175	485	155	629	660	28
3SV06	DN25	175	485	155	649	660	30.4
3SV07	DN25	175	485	155	711	660	30.8
3SV08	DN25	175	485	155	731	660	35.9
3SV09	DN25	175	485	155	751	660	38.4
3SV10	DN25	175	485	155	771	660	38.8
3SV11	DN25	175	485	155	791	660	39.2
3SV12	DN25	175	485	155	811	660	39.6
5SV02	DN32	175	485	155	557	660	27.2
5SV03	DN32	175	485	155	604	660	29.7
5SV04	DN32	175	485	155	624	660	30.1
5SV05	DN32	175	485	155	696	660	35.5
5SV06	DN32	175	485	155	716	660	37.6
5SV07	DN32	175	485	155	746	660	38
5SV08	DN32	175	485	155	766	660	38.5
10SV01	DN40	190	500	160	700	690	39.4
10SV02	DN40	190	500	160	700	690	40.3
10SV03	DN40	190	500	160	732	690	43

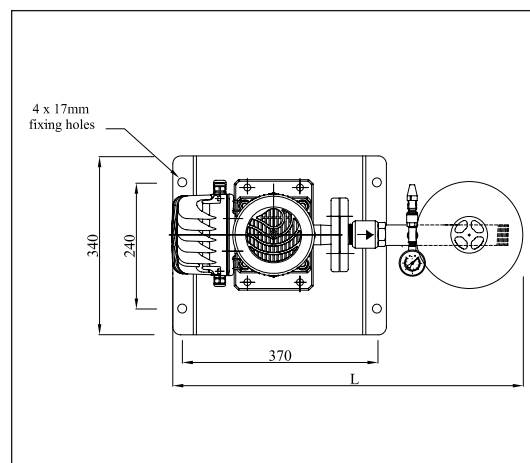

GTKS20 SERIES DIMENSION DETAILS HORIZONTAL PUMPS

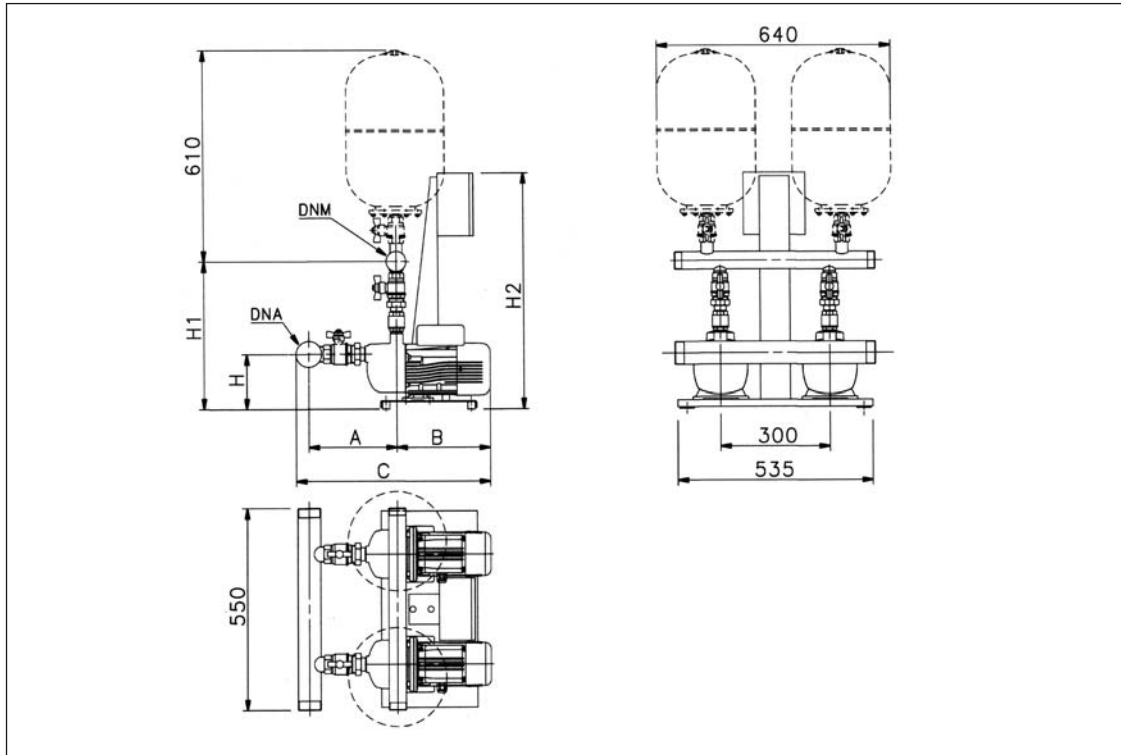

GTKS20	DNA	DNM	A	B	C	H	H1	Kg
2HM3ZT/UK	R2"	R1 1/2"	241	249	520	149	382	640
2HM5ZT/UK	R2"	R1 1/2"	291	249	570	149	382	640
2HM7ZT/UK	R2"	R1 1/2"	316	308	654	141	374	640
4HM5ZT/UK	R2"	R1 1/2"	266	249	545	149	382	640
4HM7ZT/UK	R2"	R1 1/2"	291	308	629	141	374	640
4HM9ZT/UK	R2"	R1 1/2"	316	308	654	141	374	640
CEA120/5-V/UK	R2"	R1 1/2"	196	320	546	134	476	640
CA70/33-V/UK	R2"	R1 1/2"	276	289	595	128	435	640
CA70/44-V/UK	R2"	R1 1/2"	269	289	588	128	435	640

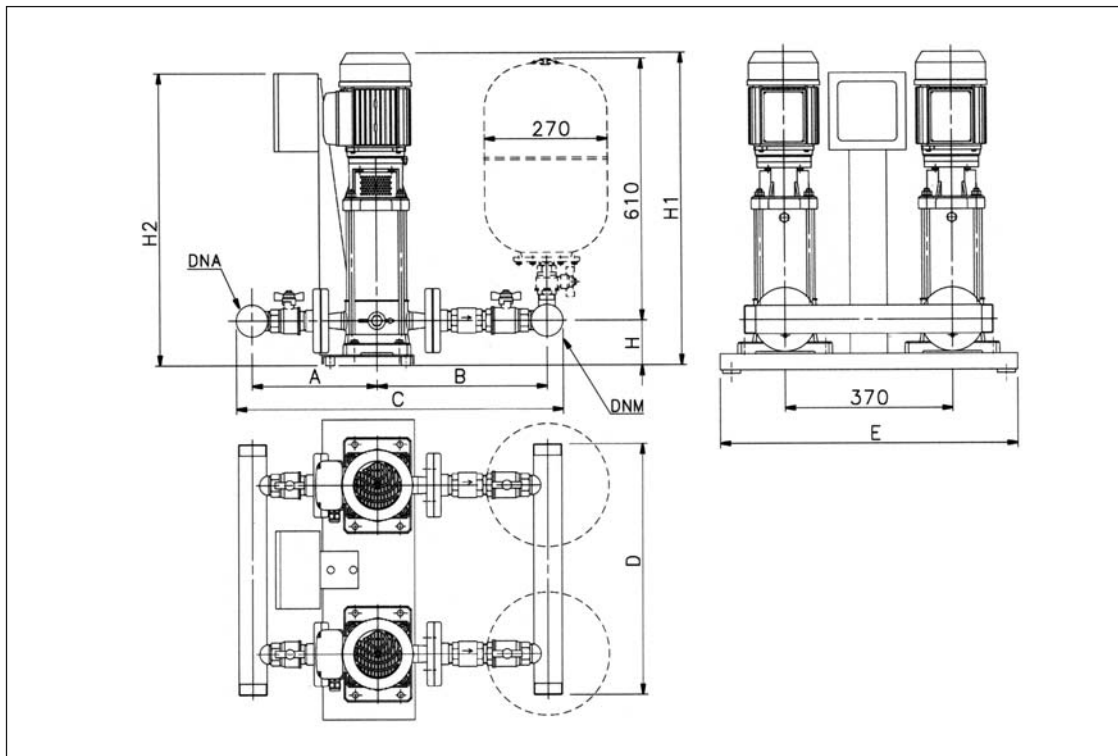
GTKS20 SERIES DIMENSION DETAILS VERTICAL PUMPS

GTKS20	DNA	DNM	A	B	C	D	E	H	H1	H2	Kg
3SV07F007T/UK	R2"	R2"	252	304	616	610	658	98	654	629	80
3SV09F011T/UK	R2"	R2"	252	304	616	610	658	98	694	629	80
3SV11F011T/UK	R2"	R2"	252	304	616	610	658	98	734	629	80
5SV03F005T/UK	R2"	R2"	265	327	652	610	658	98	547	629	80
5SV05F007T/UK	R2"	R2"	265	327	652	610	658	98	639	629	80
5SV08F011T/UK	R2"	R2"	265	327	652	610	658	98	714	629	90
10SV03F011T/UK	R2 1/2"	R2 1/2"	297	362	735	610	682	114	686	640	100

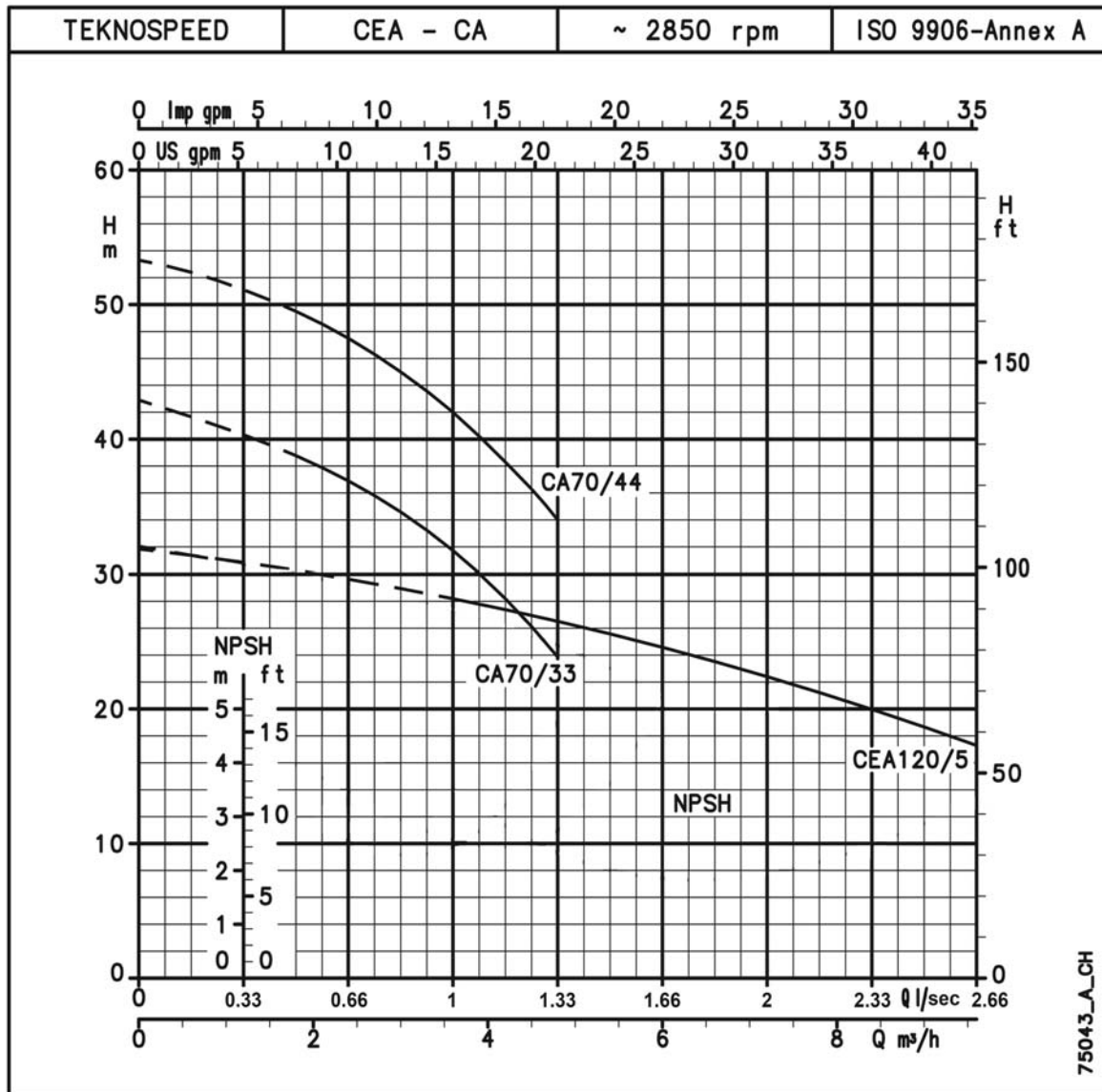
BG7 - BG11 SERIES, GTKS CURVES
OPERATING CHARACTERISTICS AT 50 Hz, 2 POLES

These performances are valid for liquids with density $\rho = 1.0 \text{ kg/dm}^3$ and kinematic viscosity $\nu = 1 \text{ mm}^2/\text{s}$.
 Performance curves based on a single pump running, set losses are not included.

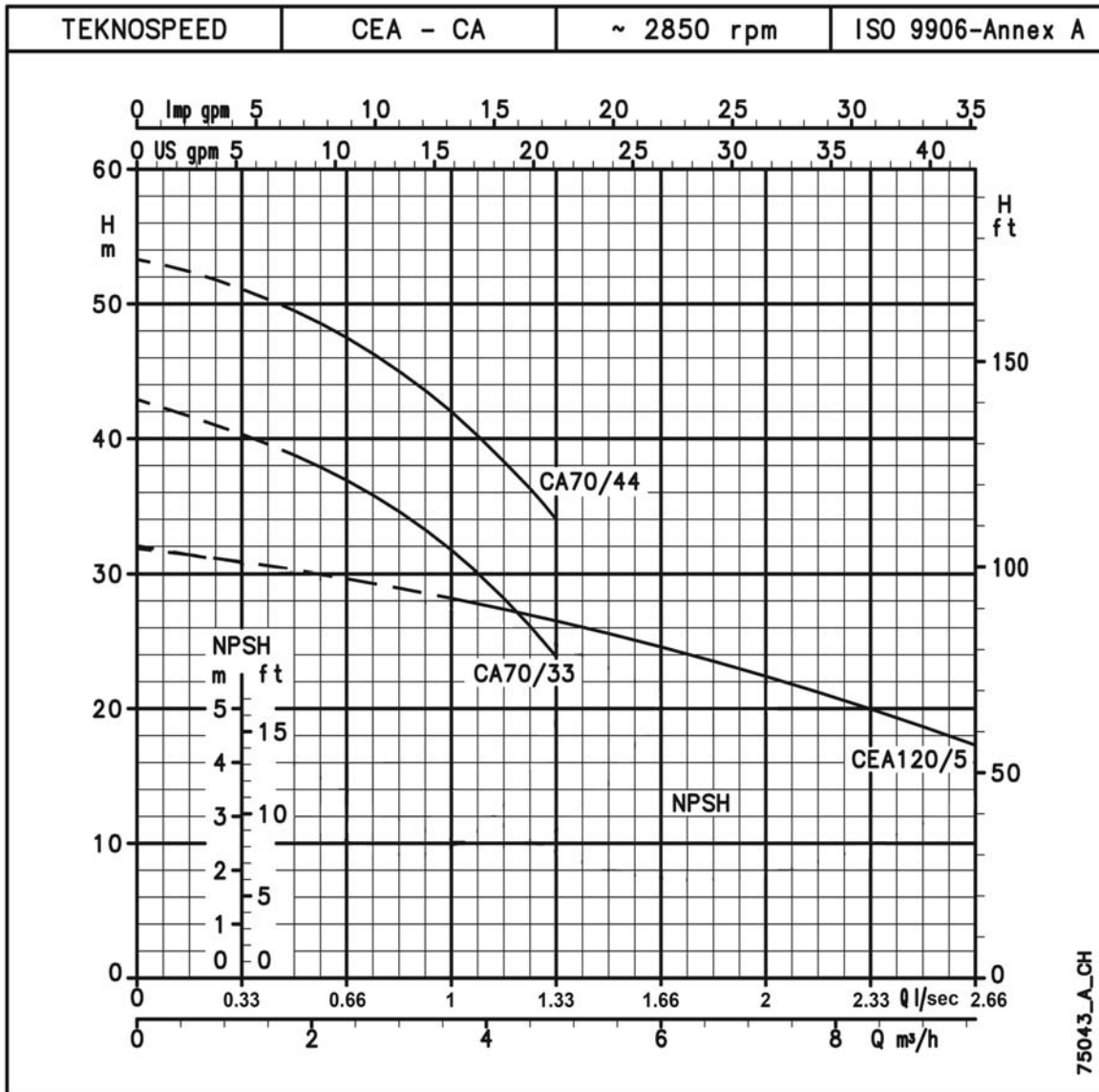
CEA - CA SERIES, GTKS CURVES
OPERATING CHARACTERISTICS AT 50 Hz, 2 POLES

These performances are valid for liquids with density $\rho = 1.0 \text{ kg/dm}^3$ and kinematic viscosity $\nu = 1 \text{ mm}^2/\text{s}$.
 Performance curves based on a single pump running, set losses are not included.

2HMZ - 4HMZ & 4HMS7 SERIES, GTKS CURVES OPERATING CHARACTERISTICS AT 50 Hz, 2 POLES

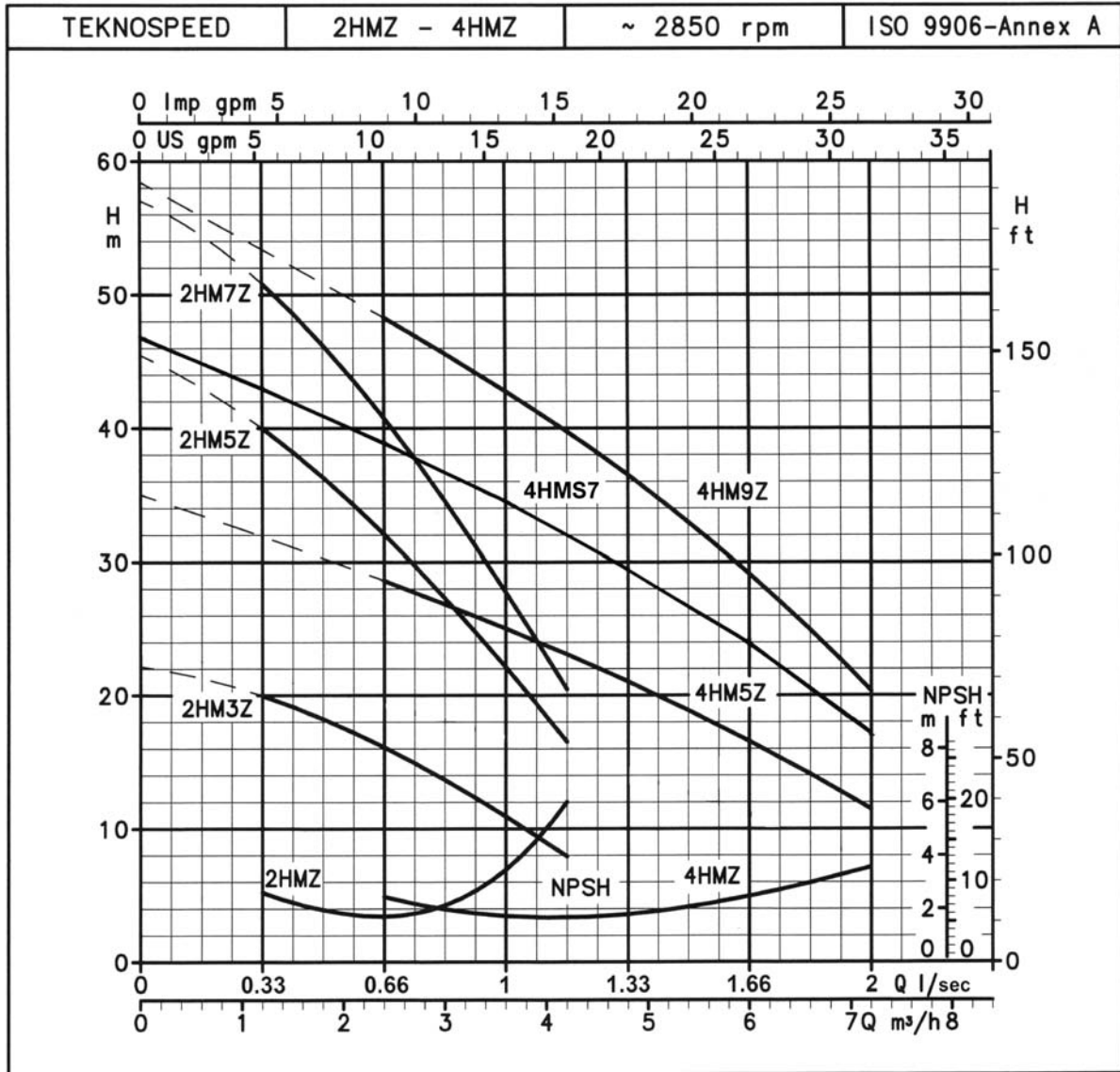

These performances are valid for liquids with density $\rho = 1.0 \text{ kg/dm}^3$ and kinematic viscosity $\nu = 1 \text{ mm}^2/\text{s}$.
Performance curves based on a single pump running, set losses are not included.

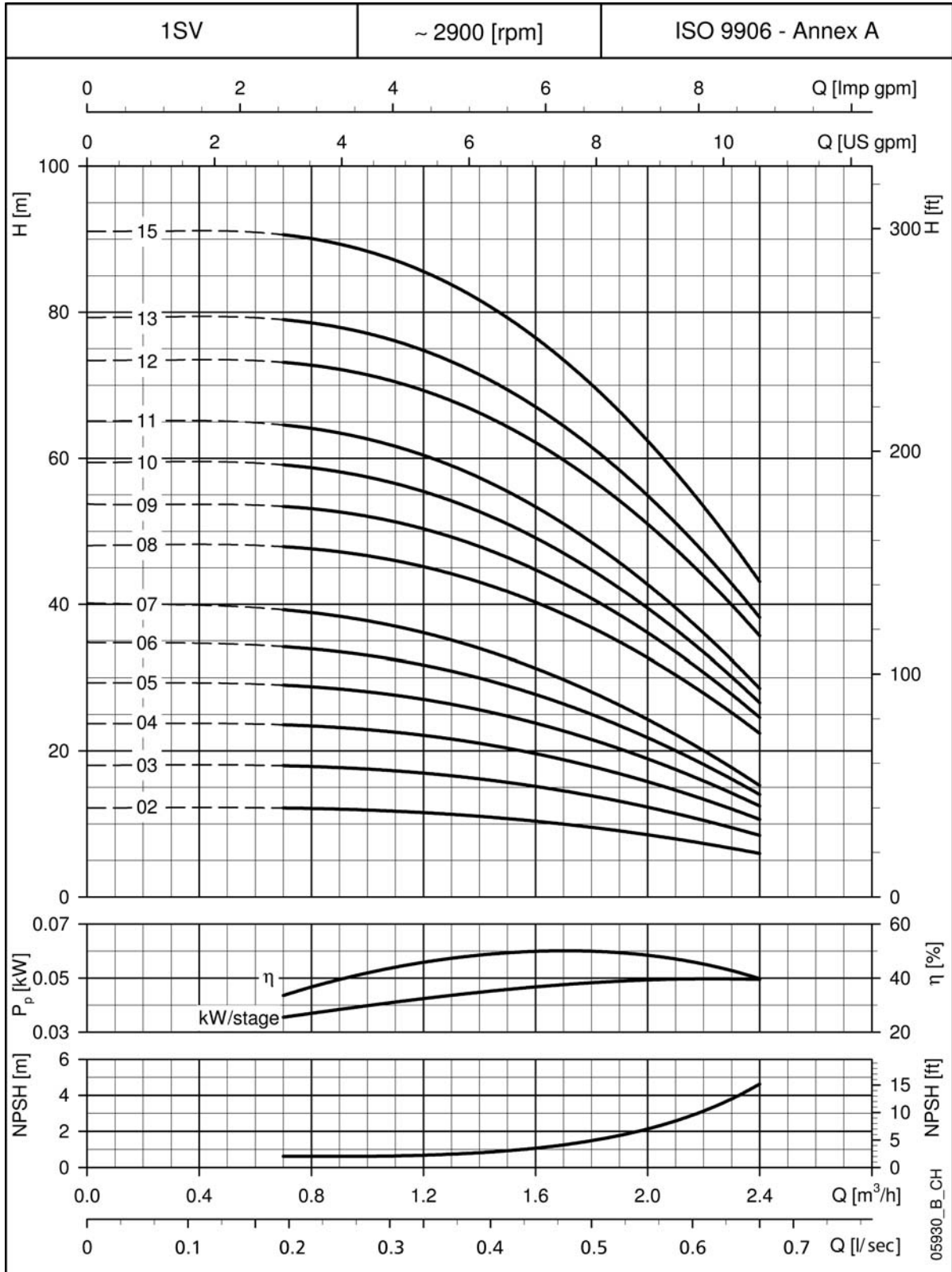
1SV SERIES, GTKS CURVES
OPERATING CHARACTERISTICS AT 50 Hz, 2 POLES

These performances are valid for liquids with density $\rho = 1.0 \text{ kg/dm}^3$ and kinematic viscosity $\nu = 1 \text{ mm}^2/\text{s}$.
Performance curves based on a single pump running, set losses are not included.

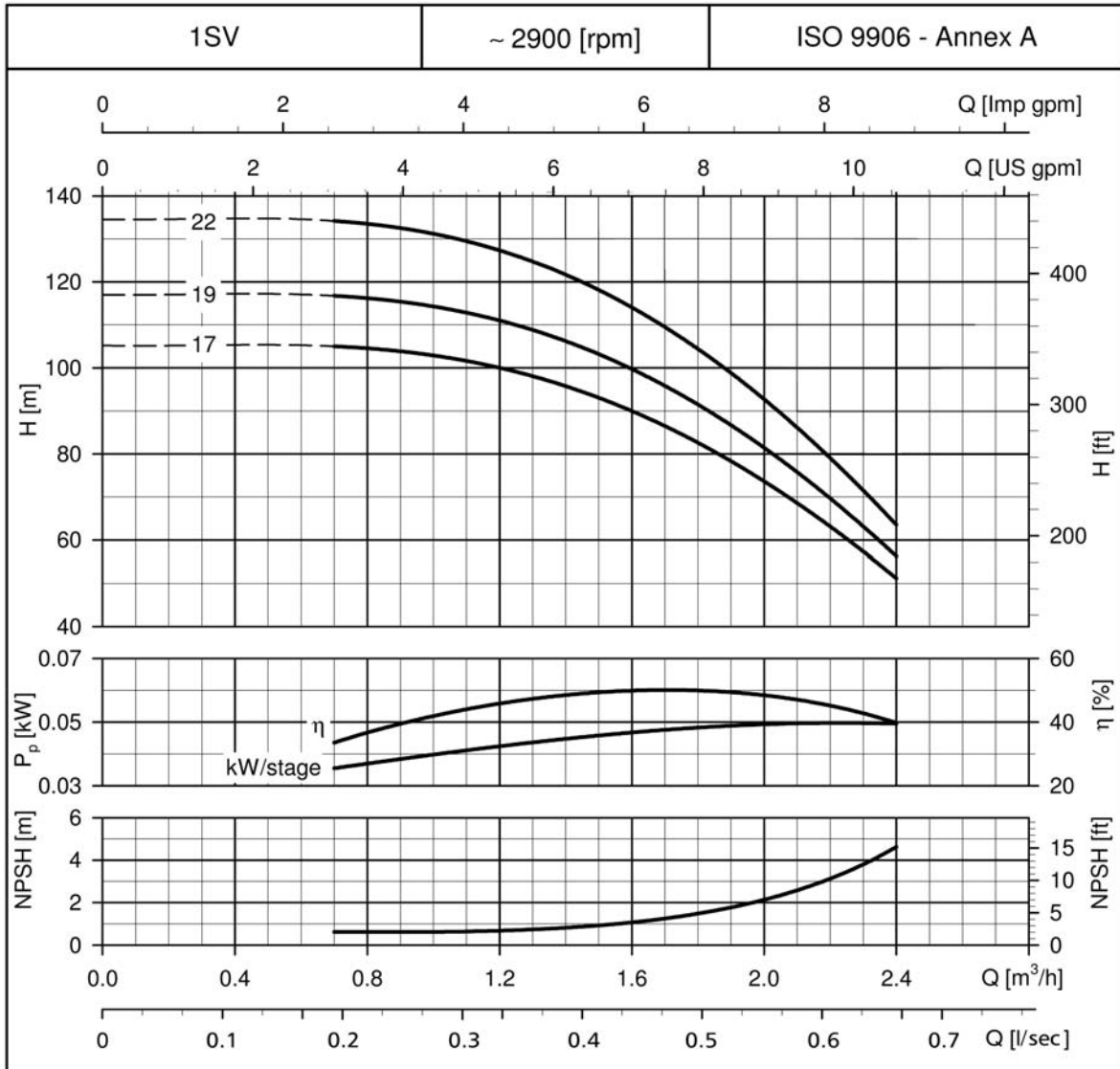
1SV SERIES, GTKS CURVES
OPERATING CHARACTERISTICS AT 50 Hz, 2 POLES

These performances are valid for liquids with density $\rho = 1.0 \text{ kg/dm}^3$ and kinematic viscosity $\nu = 1 \text{ mm}^2/\text{s}$.
 Performance curves based on a single pump running, set losses are not included.

3SV SERIES, GTKS CURVES

OPERATING CHARACTERISTICS AT 50 Hz, 2 POLES

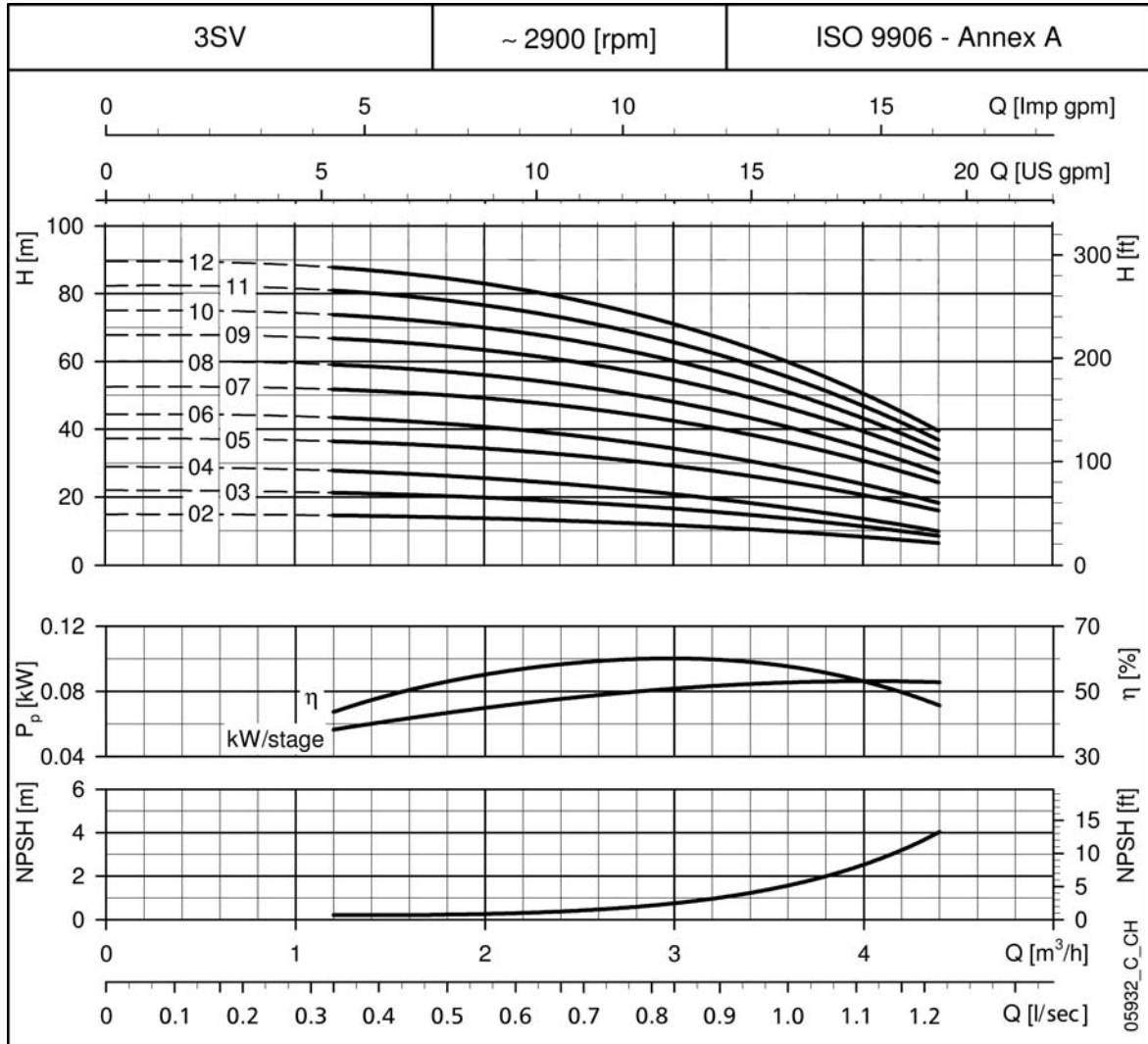

These performances are valid for liquids with density $\rho = 1.0 \text{ kg/dm}^3$ and kinematic viscosity $\nu = 1 \text{ mm}^2/\text{s}$.
 Performance curves based on a single pump running, set losses are not included.

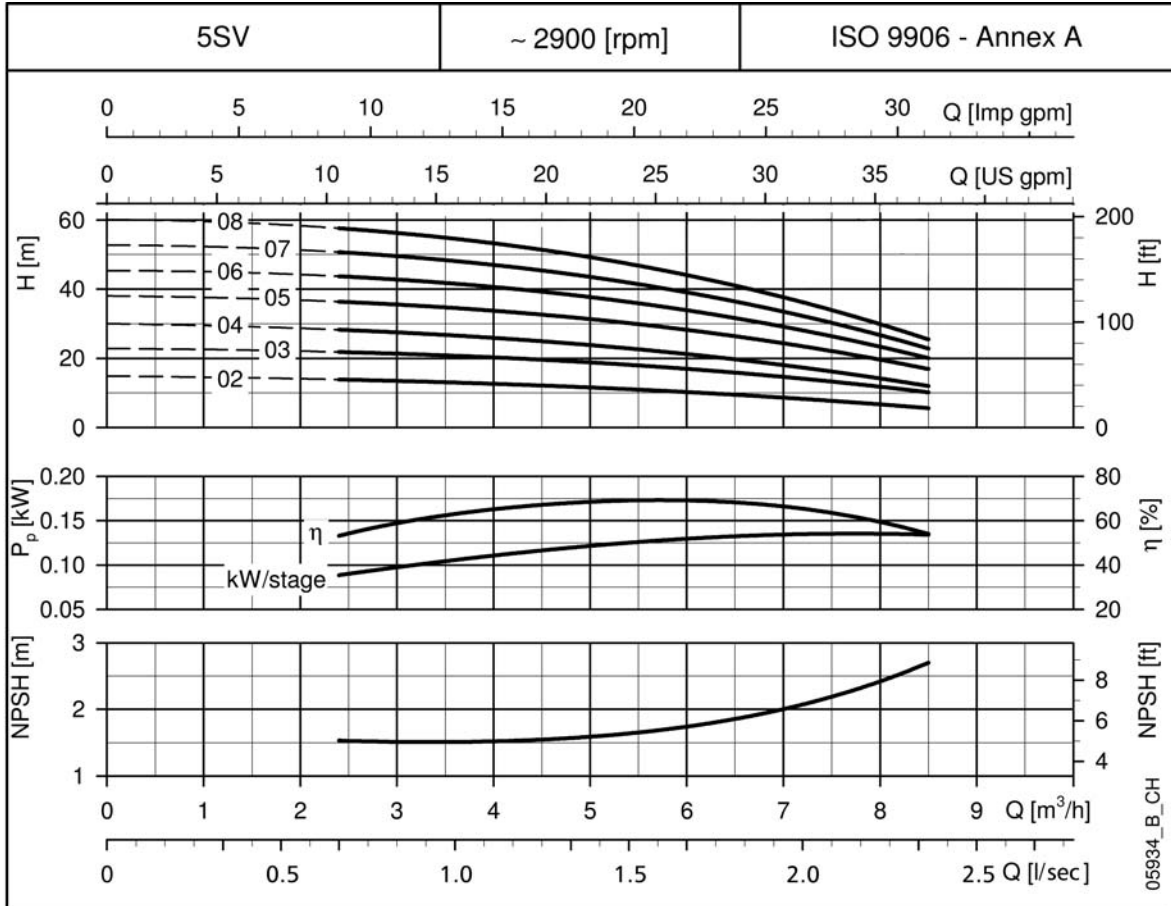
5SV SERIES, GTKS CURVES
OPERATING CHARACTERISTICS AT 50 Hz, 2 POLES

These performances are valid for liquids with density $\rho = 1.0 \text{ kg/dm}^3$ and kinematic viscosity $\nu = 1 \text{ mm}^2/\text{s}$.
 Performance curves based on a single pump running, set losses are not included.

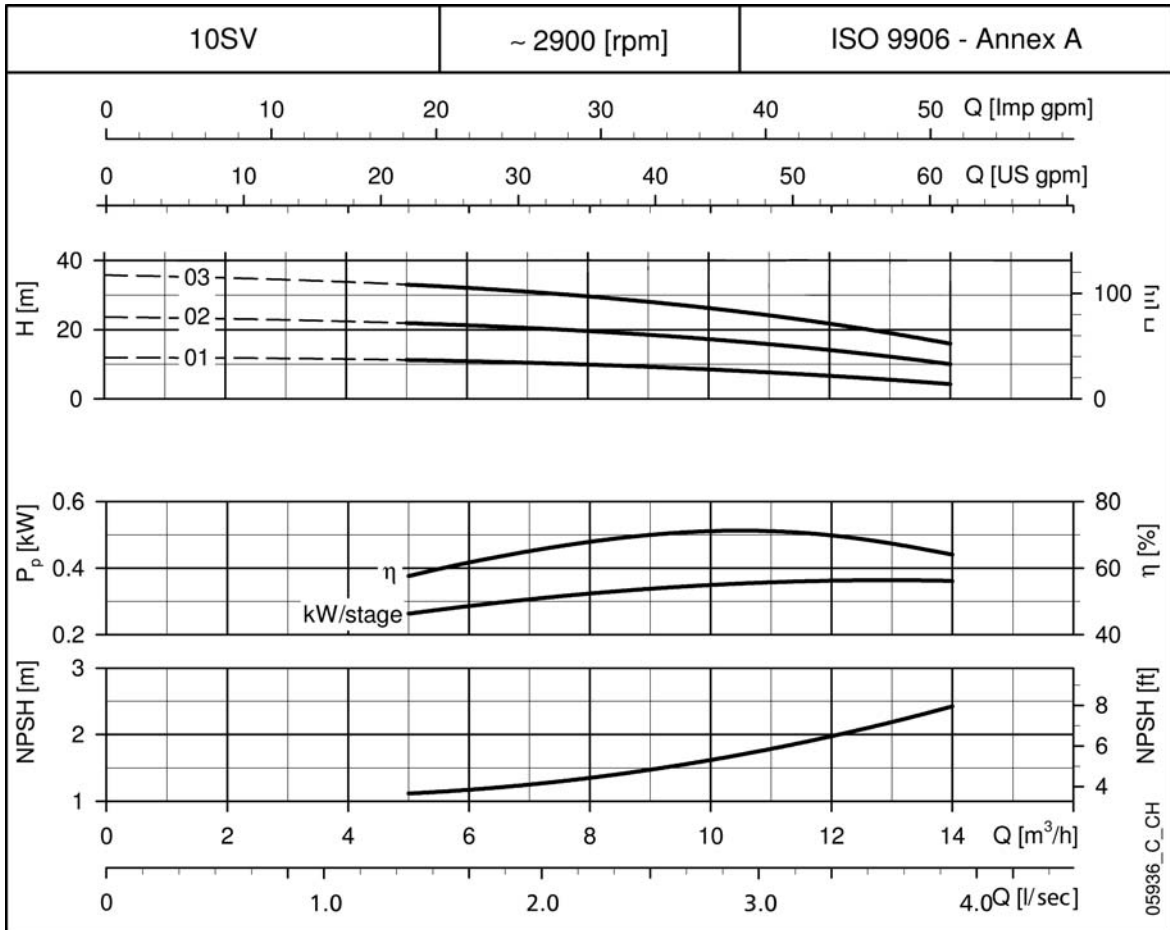
10SV SERIES, GTKS CURVES
OPERATING CHARACTERISTICS AT 50 Hz, 2 POLES

These performances are valid for liquids with density $\rho = 1.0 \text{ kg/dm}^3$ and kinematic viscosity $\nu = 1 \text{ mm}^2/\text{s}$.
 Performance curves based on a single pump running, set losses are not included.

GHV10 - GHV40 SERIES BOOSTER SET

Multi pump variable speed water booster sets with multistage vertical pumps.



SPECIFICATIONS

Number of pumps: up to 4 x 22 kW.

Delivery: up to 400 m³/h

Head: up to 150 m

Input voltage of panel

1 x 230 V 50 Hz (single-phase)

3 x 400 V 50 Hz (three-phase)

Water temperature: 0°C to +80°C

Pump type: vertical

MATERIALS

Pump: Stainless steel

Manifold: AISI 304 stainless steel

PRODUCT FEATURES AND APPLICATIONS

- Water network supply in apartments, offices, hotels, shopping centres, factories.
- Water supply to agricultural water networks (e.g. irrigation).

MAIN COMPONENTS

- 1 - 4 multistage vertical pumps, e-SV series.
- Hydrovar® frequency converters mounted on the motor of each electric pump.
- Suction manifold made of AISI 304 stainless steel, with threaded or flanged ports depending on the size of pump (see drawings).
- Discharge manifold made of AISI 304 stainless steel, with threaded or flanged ports depending on the type of pump (see drawings). Fitted with R1" threaded couplings with caps to allow connection of 24-litre diaphragm tanks.
- GHV20-40 sets have on-off valves on suction and discharge ports of each pump, ball type with threaded coupling up to 2" are used on sets up to 22SV butterfly type are used on 33SV sets and above.
- Non-return valves on discharge side of each pump, spring - loaded type, with threaded coupling up to 1" 1/2 size. 2" and above are fitted with Wafer type non return valves.
- Pressure gauge and control transmitter on the pump's discharge side.
- Miscellaneous pipe fittings made of nickel-plated brass and stainless steel.
- Pump mounting base - GHV20 & 30 sets up to 4kW have Galvanised bases all other sets have painted steel.

GHV10 - GHV40 SERIES BOOSTER SET

MAIN COMPONENTS *continued*

- Electrical control GHV10 sets are supplied without control panel GHV20 - GHV40 control made of painted steel, IP55 protection class, equipped with:
Door interlocked isolator.
- Thermal magnetic protectors for each inverter. Low water protection, ready to connect to external low water device. The panel provides protection against dry running and is ready for installation of an external device such as a minimum pressure switch, float switch or electrode probes.

Set comes pre-assembled and tested, complete with operating instructions and panel wiring diagram.

STANDARD VERSION

For drinking water applications.

The main components in contact with the liquid are certificated suitable for drinking water or are made of AISI304 or higher grade of stainless steel.

GHV20-40 fitted with vibration damping feet. All sets come complete with 1 x 24Lt vessel for each pump.

Sets with 3SV, 5SV, 10SV pumps:

Nickel plated brass valves, brass non-return valves, AISI304 stainless steel manifolds.

Sets with 15SV pumps:

Nickel plated brass valves, non-return valves with stainless steel flaps.

Sets with 22SV, 33SV, 46SV, 92SV pumps:

Valves with epoxy butterfly, non-return valves with stainless steel flaps.

AISI 316 VERSIONS

For special applications

Manifolds, valves, non-return valves and main components with parts directly in contact with the pumped liquid are made of AISI 316 stainless steel.

Accessories available on request:

- Vibration dampers kit (GHV10 sets).
- Device against dry running in one of the following versions:
float switch, for positive suction head;
minimum pressure switch, for positive suction head;
probe electrodes kit, for positive suction head.



IDENTIFICATION CODES

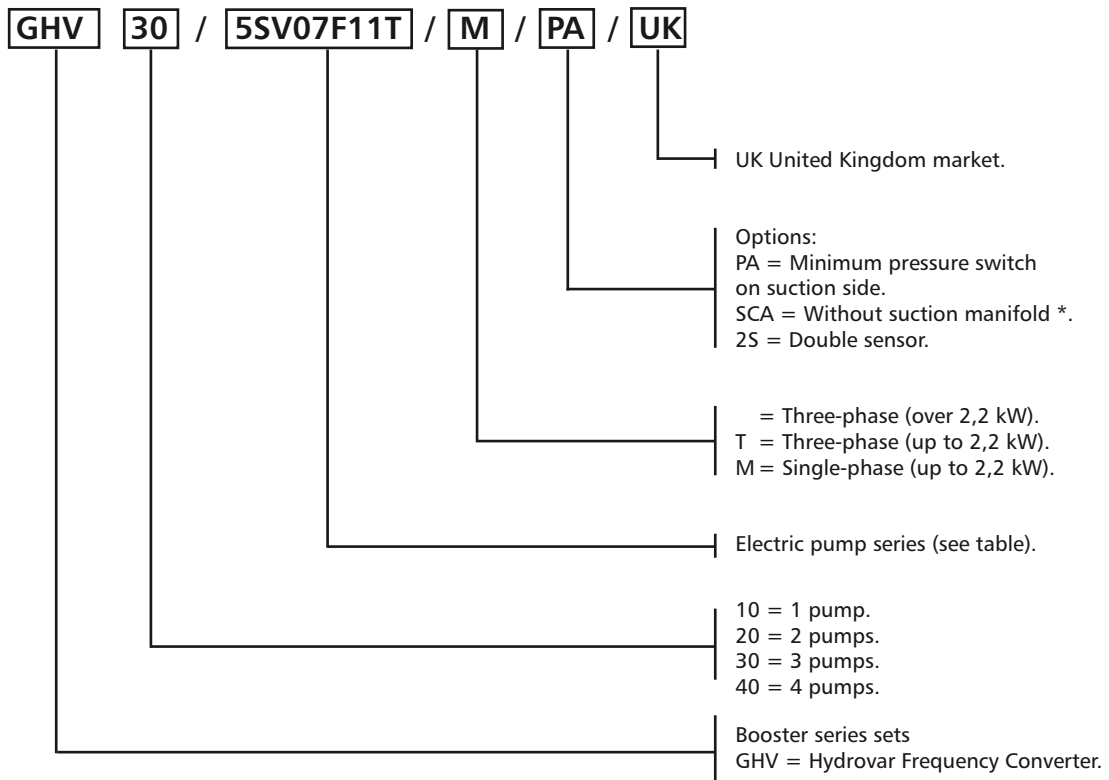

SPECIAL VERSIONS

Special versions featuring different material/operating temperatures and electrical panels with additional functions are available on request.

Booster Sets which are above 16bar pressure rating are available on request.

CONTROL PANEL AND BASIC CONNECTION DETAILS

GHV10 single phase booster set 1.5-2.2Kw

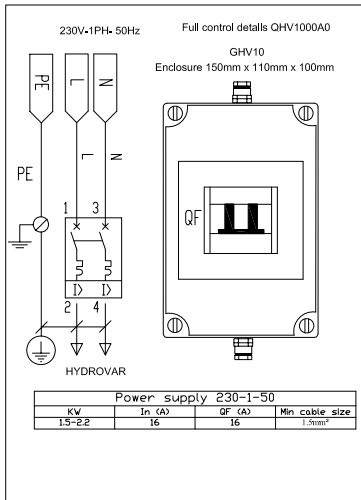

GHV10 three phase booster set 2.2-45,0Kw

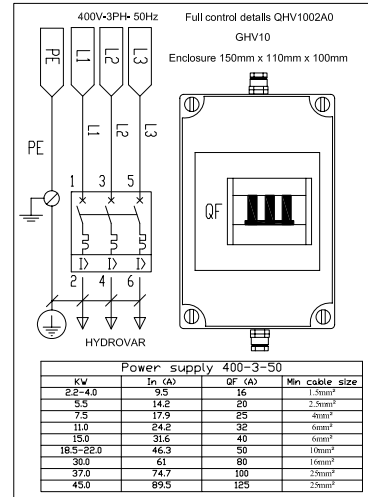

GHV20 single phase booster set 1.5-2.2Kw

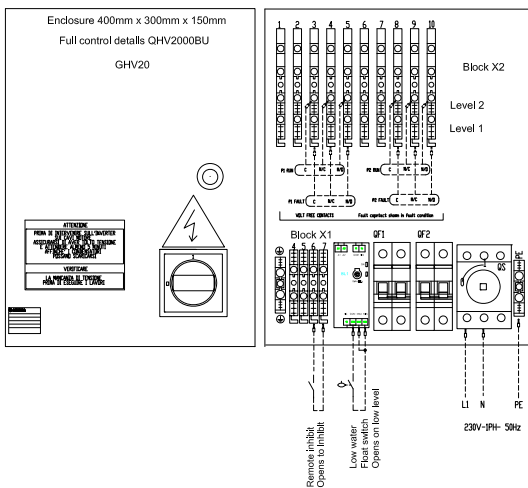

GHV20 three phase booster set 2.2-22Kw

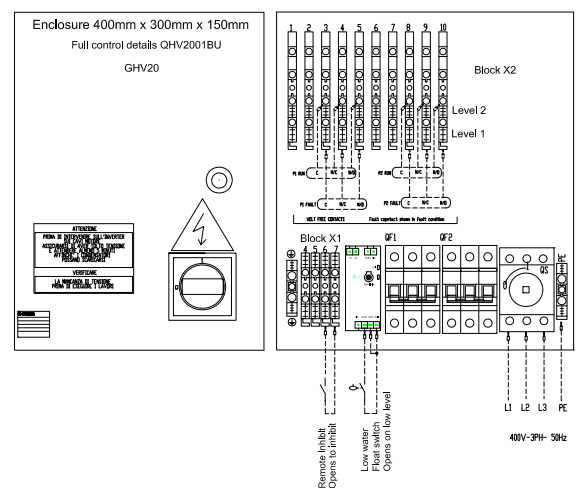

CONTROL PANEL AND BASIC CONNECTION DETAILS

GHV30 single phase booster set 1.5-2.2Kw

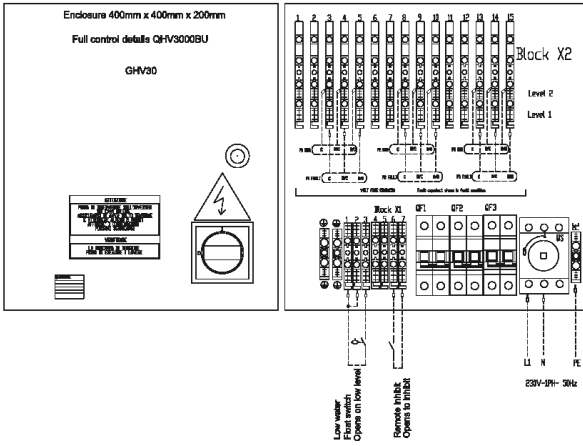

GHV30 three phase booster set 2.2-22Kw

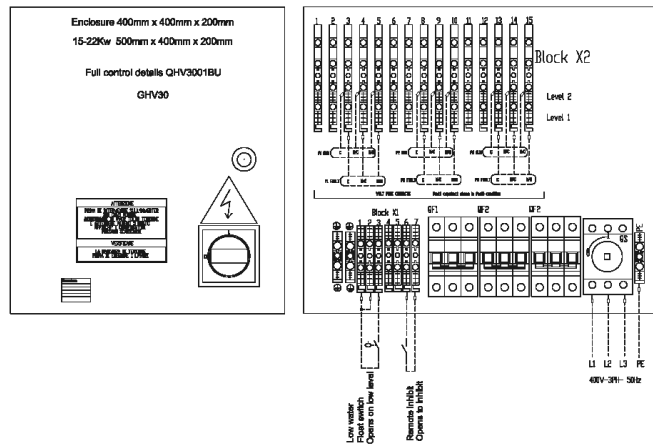

GHV40 single phase booster set 1.5-2.2Kw

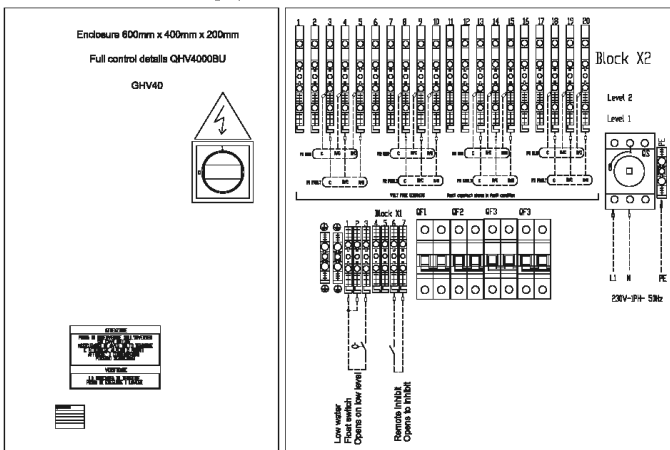

GHV40 three phase booster set 2.2-22Kw

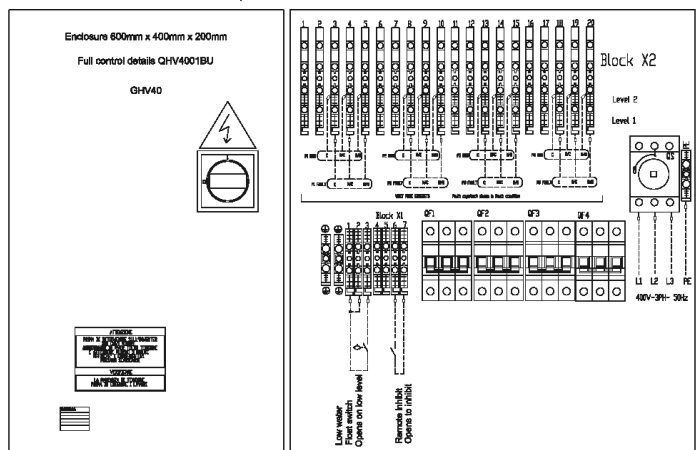

1, 3 and 5SV SERIES HYDRAULIC PERFORMANCE TABLE AT 50 Hz, 2 POLES

PUMP TYPE	RATED POWER		Q = DELIVERY														
			l/min	12	20	25	30	35	40	45	50	60	73	100	120	141	
			m ³ /h	0.7	1.2	1.5	1.8	2.1	2.4	2.7	3	3.6	4.4	6.0	7.2	8.5	
kW		HP	H = TOTAL HEAD IN METRES OF COLUMN WATER														
1SV12	0.75	1	73.3	73.1	69.3	64.3	57.1	47.6	35.7								
1SV13	0.75	1	79.2	78.9	74.8	69.4	61.6	51.2	38.2								
1SV15	0.75	1	90.9	90.5	85.6	79.3	70.1	58.1	43.1								
1SV17	1.1	1.5	105.2	104.9	100.0	93.1	82.6	68.6	51.2								
1SV19	1.1	1.5	117.0	116.7	111.0	103.2	91.5	75.8	56.3								
1SV22	1.1	1.5	134.6	134.1	127.4	118.1	104.4	86.1	63.5								
1SV25	1.5	2	152.6	152.4	145.5	135.4	120.0	99.1	72.7								
3SV07	5.5	0.75	52.5		51.8	51.0	50.0	48.7	47.0	45.0	42.5	36.1	24.6				
3SV08	0.75	1	60.0		59.1	58.2	57.0	55.4	53.4	51.0	48.1	40.7	27.5				
3SV09	1.1	1.5	67.7		66.8	65.8	64.5	62.8	60.6	57.9	54.6	46.4	31.6				
3SV10	1.1	1.5	75.0		73.8	72.7	71.3	69.3	66.9	63.8	60.2	51.0	34.5				
3SV11	1.1	1.5	82.3		81.0	79.7	78.0	75.8	73.1	69.7	65.7	55.5	37.4				
3SV12	1.1	1.5	89.6		87.8	86.4	84.5	82.1	79.1	75.5	71.1	59.9	40.1				
3SV13	1.5	2	98.1		96.7	95.4	93.5	91.0	87.8	83.9	79.2	67.2	45.6				
3SV14	1.5	2	105.6		104.1	102.5	100.4	97.7	94.2	89.9	84.8	71.8	48.5				
3SV16	1.5	2	119.9		117.8	116.1	113.6	110.5	106.5	101.6	95.8	80.9	54.2				
3SV19	2.2	3	144.3		142.3	140.3	137.5	133.9	129.2	123.5	116.7	99.1	67.6				
3SV21	2.2	3	159.3		156.9	154.6	151.4	147.3	142.1	135.7	128.0	108.5	73.6				
5SV05	0.75	1	38.0						36.4	36.0	35.5	34.5	32.9	28.2	23.5	17.1	
5SV06	1.1	1.5	45.3						43.7	43.3	42.8	41.6	39.6	33.9	28.1	20.3	
5SV07	1.1	1.5	52.7						50.7	50.1	49.5	48.1	45.8	39.1	32.2	23.1	
5SV08	11	1.5	60.1						57.6	57.0	56.2	54.6	51.8	44.1	36.2	25.8	
5SV09	1.5	2	68.0						65.5	64.8	64.0	62.2	59.3	50.6	41.9	30.2	
5SV10	1.5	2	75.5						72.4	71.7	70.8	68.7	65.4	55.7	46.0	33.0	
5SV11	1.5	2	82.8						79.3	78.4	77.5	75.2	71.4	60.7	49.9	35.6	
5SV12	2.2	3	90.8						88.0	87.0	86.0	83.4	79.3	67.4	55.7	40.5	
5SV13	2.2	3	98.3						95.0	94.0	92.8	90.0	85.5	72.6	59.9	43.5	
5SV14	2.2	3	105.7						102.0	100.9	99.6	96.6	91.7	77.8	64.0	46.3	
5SV15	2.2	3	113.1						109.0	107.8	106.4	103.1	97.8	82.8	68.1	49.1	
5SV16	2.2	3	120.5						115.9	114.6	113.1	109.6	103.9	87.8	72.1	51.8	
5SV18	3	4	135.8						131.1	129.7	128.0	124.1	117.8	99.9	82.3	59.5	
5SV21	3	4	157.9						152.0	150.3	148.3	143.6	136.1	114.9	94.2	67.6	

10, 15, 22SV SERIES HYDRAULIC PERFORMANCE TABLE AT 50 Hz, 2 POLES

PUMP TYPE	RATED POWER		Q = DELIVERY													
			l/min 0	83.34	100	133	170	183.34	233	270	330	350	400	430	460	483.33
	kW	HP	m ³ /h 0	5.0	6.0	8.0	10.2	11.0	14.0	16.2	19.8	21.0	24.0	25.8	27.6	29.0
H = TOTAL HEAD IN METRES OF COLUMN OF WATER																
10SV02	0.75	1	23.6	21.9	21.3	19.6	17.0	15.8	10.0							
10SV03	1.1	1.5	35.7	33.0	32.1	29.6	25.8	24.1	16.0							
10SV04	1.5	2	47.7	44.2	43.0	39.9	34.8	32.6	21.7							
10SV05	2.2	3	60.0	56.1	54.7	50.9	44.9	42.2	29.0							
10SV06	2.2	3	71.8	66.8	65.0	60.4	53.1	49.8	33.9							
10SV07	3	4	83.6	78.3	76.2	70.8	62.1	58.3	39.8							
10SV08	3	4	95.3	88.9	86.5	80.1	70.2	65.7	44.5							
10SV09	4	5.5	106.3	100.1	97.5	90.8	80.0	75.1	52.1							
10SV10	4	5.5	118.0	110.8	107.9	100.3	88.2	82.8	57.2							
10SV11	4	5.5	129.6	121.3	118.1	109.6	96.3	90.3	62.1							
10SV13	5.5	7.5	156.0	146.5	142.7	132.6	116.4	109.2	74.3							
15SV02	2.2	3	28.7			26.7	25.9	25.5	23.9	22.4	18.9	17.4	13.1			
15SV03	3	4	43.3			40.4	39.1	38.6	36.2	33.8	28.7	26.5	20.1			
15SV04	4	5.5	58.4			54.7	53.1	52.5	49.4	46.3	39.7	36.9	28.7			
15SV05	4	5.5	72.7			67.8	65.8	65.0	61.0	57.1	48.7	45.2	34.9			
15SV06	5.5	7.5	87.6			81.5	79.4	78.4	74.1	69.9	60.3	56.3	44.2			
15SV07	5.5	7.5	101.9			94.5	91.9	90.8	85.7	80.6	69.4	64.7	50.5			
15SV08	7.5	10	117.4			110.9	108.0	106.8	100.8	94.9	82.0	76.7	60.6			
15SV09	7.5	10	131.9			124.4	121.0	119.6	112.8	106.1	91.5	85.5	67.4			
15SV10	11	15	147.7			138.8	135.3	133.8	126.7	119.6	103.9	97.4	77.5			
15SV11	11	15	162.3			152.4	148.5	146.8	138.9	131.1	113.8	106.5	84.7			
22SV01	1.1	1.5	14.7					13.5	12.7	12.0	10.4	9.7	7.7	6.3	4.7	3.4
22SV02	2.2	3	30.4					28.4	27.2	26.0	23.3	22.2	18.9	16.6	13.8	11.5
22SV03	3	4	45.4					42.2	40.4	38.5	34.5	32.8	27.8	24.2	20.2	16.6
22SV04	4	5.5	60.9					56.8	54.4	51.9	46.6	44.4	37.9	33.1	27.7	23.0
22SV05	5.5	7.5	76.0					70.9	67.9	64.9	58.3	55.6	47.4	41.4	34.7	28.8
22SV06	7.5	10	93.2					88.8	85.7	82.5	75.4	72.4	63.3	56.7	49.1	42.6
22SV07	7.5	10	108.5					103.1	99.4	95.7	87.2	83.7	73.1	65.3	56.5	48.8
22SV08	11	15	124.6					119.2	115.2	111.0	101.6	97.7	85.7	77.0	66.9	58.2
22SV09	11	15	140.1					133.7	129.2	124.4	113.8	109.3	95.8	86.0	74.6	64.8
22SV10	11	15	155.4					148.2	143.1	137.8	125.9	120.9	105.8	94.8	82.3	71.3

33, 46SV SERIES

HYDRAULIC PERFORMANCE TABLE AT 50 Hz, 2 POLES

PUMP TYPE	RATED POWER		Q = DELIVERY										
			l/min 0	250	300	367	417	500	583	667	750	900	1000
	kW	HP	m ³ /h 0	15	18	22	25	30	35	40	45	54	60
H = TOTAL HEAD METRES COLUMN OF WATER													
33SV1/1A	2.2	3	17.4	16.2	15.7	15	14	12.2	9.8	6.7			
33SV1	3	4	23.8	21.7	21.2	20	20	17.8	15.5	12.7			
33SV2/2A	4	5.5	35.1	34.1	33.3	32	30	27	22.4	16.6			
33SV2/1A	4	5.5	40.8	38.8	37.9	36	35	32	27.5	22.3			
33SV2	5.5	7.5	47.8	45	44.1	43	41	39	35	29.9			
33SV3/2A	5.5	7.5	57.7	55.2	53.8	51	49	44	38	29.6			
33SV3/1A	7.5	10	64.5	61.3	60	58	56	51	45	37			
33SV3	7.5	10	71.5	67.4	66.0	64	62	58	52.0	44.6			
33SV4/2A	7.5	10	82	78.8	77	74	72	66	58	47.2			
33SV4/1A	11	15	88.9	85	83	81	78	73	65	55.1			
33SV4	11	15	95.9	91.1	90	87	85	80	73	63.1			
33SV5/2A	11	15	106	101.6	100	96	93	85	76	63			
33SV5/1A	11	15	112.7	107.2	105	102	99	92	82	70			
33SV5	15	20	120.4	114.9	113	110	107	101	92	80.5			
33SV6/2A	15	20	131.2	126.9	125	120	116	108	96	81.2			
33SV6/1A	15	20	139.1	133.5	131	128	124	116	105	90.4			
33SV6	15	20	145.6	139	137	133	129	121	110	96.1			
33SV7/2A	15	20	156	149.9	147	143	138	128	115	98.2			
33SV7/1A	18.5	25	163.3	156.6	154	150	145	136	123	106.2			
46SV1/1A	3	4	19.5			19.2	18.8	17.9	16.7	15.1	13.1	8.5	4.6
46SV1	4	5.5	27.2			24	23.5	22.5	21.4	19.9	18.2	14.3	10.8
46SV2/2A	5.5	7.5	38.8			39.8	39.2	37.8	35.7	32.9	29.4	21.1	13.9
46SV2	7.5	10	52.6			48.5	47.7	46.1	44.2	41.7	38.7	31.4	25.1
46SV3/2A	11	15	64.7			65.1	64	62	60	56	52	40.4	30.8
46SV3	11	15	80.8			74.3	73	71	68	65	60	50	40.7
46SV4/2A	15	20	92.4			90.7	90	87	83	79	73	58	45.6
46SV4	15	20	107.3			99.8	98	96	92	87	82	68	55.9
46SV5/2A	18.5	25	117.2			114.8	113	110	106	100	93	75	60.2
46SV5	18.5	25	134.5			125.1	123	120	116	110	103	86	71.5
46SV6/2A	22	30	143.7			139.3	138	134	129	122	113	92	73.4
46SV6	22	30	161			149.9	148	144	139	132	124	104	86

66, 92SV SERIES HYDRAULIC PERFORMANCE TABLE AT 50 Hz, 2 POLES

PUMP TYPE	RATED POWER		Q = DELIVERY												
			l/min 0	500	600	700	750	900	1000	1200	1300	1417	1600	1800	2000
	kW	HP	m ³ /h 0	30	36	42	45	54	60	72	78	85	96	108	120
H = TOTAL HEAD METRES COLUMN OF WATER															
66SV1/1A	4	5.5	23.8	21.4	20.7	19.9	19.4	17.8	16.6	13.3	11.2	8.3			
66SV1	5.5	7.5	29.2	25.8	24.8	23.8	23.3	21.8	20.7	17.9	16.1	13.5			
66SV2/2A	7.5	10	47.5	42.6	41.2	39.5	38.6	36	32.9	26.4	22.2	16.4			
66SV2/1A	11	15	54.2	49.6	48.2	46.7	45.8	42.9	40.6	34.8	31.2	26.2			
66SV2	11	15	60.4	55.7	54.4	52.8	52	49.3	47.1	42	38.9	34.7			
66SV3/2A	15	20	78.4	71.6	70	67	66	62	58	49	43.3	35.3			
66SV3/1A	15	20	84.7	77.8	76	74	72	68	65	56	51	44.0			
66SV3	18.5	25	91.4	84.7	83	81	79	75	72	64	60	53.5			
66SV4/2A	18.5	25	108.9	99.6	97	94	92	86	82	70	63	52.8			
66SV4/1A	22	30	115.2	105.9	103	100	99	93	89	78	71	61.8			
66SV4	22	30	121.6	112.5	110	107	105	100	96	86	79	70.8			
92SV1/1A	5.5	7.5	24.5				22.2	21.5	20.9	19.4	18.5	17.3	15	11.8	7.9
92SV1	7.5	10	33.5				28.7	27.2	26.2	24.3	23.3	22.2	20.2	17.6	14.3
92SV2/2A	11	15	49.4				45.1	43.7	42.5	39.6	37.9	35.5	30.9	24.6	16.8
92SV2	15	20	67.8				58.2	55	53	49.5	47.6	45.2	41.4	36.3	29.6
92SV3/2A	18.5	25	82.4				74.4	72	70	65	62	59	52	43.6	32.9
92SV3	22	30	102.2				88.2	84	81	76	73	69	63	56	46.3
92SV4/2A	30	40	115.7				104	100	97	90	87	82	74	63	49
92SV4	30	40	133.1				117	112	108	101	97	92	85	75	62.5
92SV5/2A	37	50	149				133.2	128	124	116	111	105	95	81	64.6

GHV10 SERIES 2 PUMP BOOSTER SETS DIMENSIONS,

GHV10	DNA/DNM	A	B	H	H1	L	Kg
1SV12	DN25	175	519	155	981	694	39
1SV13	DN25	175	519	155	981	694	39
1SV15	DN25	175	519	155	1041	694	40
1SV17	DN25	175	519	155	1081	694	43
1SV19	DN25	175	519	155	1121	694	44
1SV22	DN25	175	519	155	1181	694	45
1SV25	DN25	175	519	155	1286	694	51
3SV07	DN25	175	519	155	881	694	32
3SV08	DN25	175	519	155	901	694	37
3SV09	DN25	175	519	155	921	694	40
3SV10	DN25	175	519	155	941	694	40
3SV11	DN25	175	519	155	961	694	41
3SV12	DN25	175	519	155	981	694	41
3SV13	DN25	175	519	155	1046	694	46
3SV14	DN25	175	519	155	1066	694	53
3SV16	DN25	175	519	155	1106	694	53
3SV19	DN25	175	519	155	1166	694	57
3SV21	DN25	175	519	155	1206	694	58
5SV05	DN25	175	519	155	866	694	37
5SV06	DN25	175	519	155	891	694	39
5SV07	DN25	175	519	155	916	694	39
5SV08	DN25	175	519	155	941	694	40
5SV09	DN25	175	519	155	1011	694	46
5SV10	DN25	175	519	155	1036	694	47
5SV11	DN25	175	519	155	1061	694	47
5SV12	DN25	175	519	155	1086	694	48
5SV13	DN25	175	519	155	1111	694	48
5SV14	DN32	175	519	155	1136	694	56
5SV15	DN32	175	519	155	1161	694	56
5SV16	DN32	175	519	155	1186	694	57
5SV18	DN32	175	519	155	1246	694	61
5SV21	DN32	175	519	155	1281	694	63
10SV01	DN40	190	534	160	870	724	41
10SV02	DN40	190	534	160	870	724	42
10SV03	DN40	190	534	160	902	724	45
10SV04	DN40	190	534	160	979	724	49
10SV05	DN40	190	534	160	1009	724	52
10SV06	DN40	190	534	160	1043	724	53
10SV07	DN40	190	534	160	1085	724	58
10SV08	DN40	190	534	160	1117	724	59
10SV09	DN40	190	534	160	1170	724	72
10SV10	DN40	190	534	160	1202	724	73
10SV11	DN40	190	534	160	1234	724	74
10SV13	DN40	190	534	160	1421	724	97

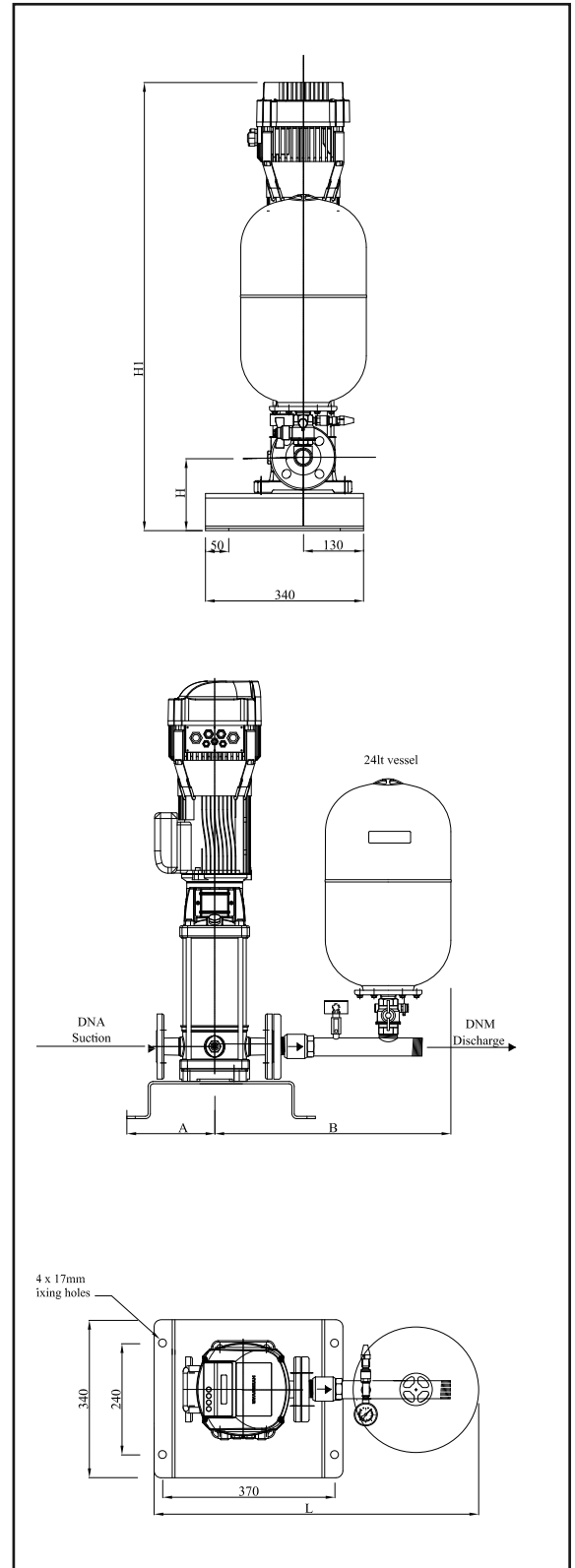

Dimensions in mm. Tolerance ± 10 mm.
 Antivibration feet will add 25mm to the set height.

GHV10 SERIES 2 PUMP BOOSTER SETS DIMENSIONS,

GHV10	DNA/DNM	H1	Kg
15SV01	DN50	742	56
15SV02	DN50	787	62
15SV03	DN50	845	67
15SV04	DN50	914	74
15SV05	DN50	962	77
15SV06	DN50	1133	100
15SV07	DN50	1181	101
15SV08	DN50	1221	128
15SV09	DN50	1269	130
15SV10	DN50	1408	148
15SV11	DN50	1456	149
22SV01	DN50	742	46
22SV02	DN50	787	53
22SV03	DN50	845	58
22SV04	DN50	914	65
22SV05	DN50	1085	86
22SV06	DN50	1125	105
22SV07	DN50	1173	114
22SV08	DN50	1312	132
22SV09	DN50	1360	133
22SV10	DN50	1408	135

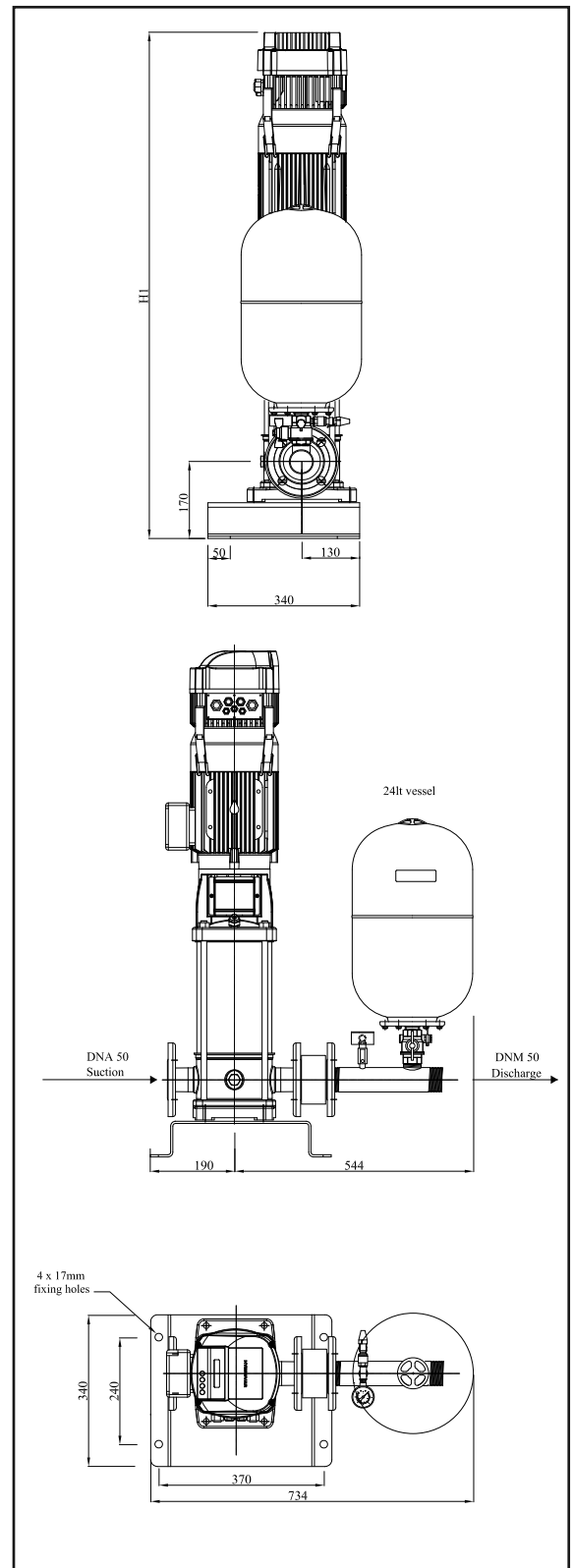

Dimensions in mm. Tolerance ± 10 mm.
Antivibration feet will add 25mm to the set height.

GHV20 SERIES 2 PUMP BOOSTER SETS DIMENSIONS, R VERSION

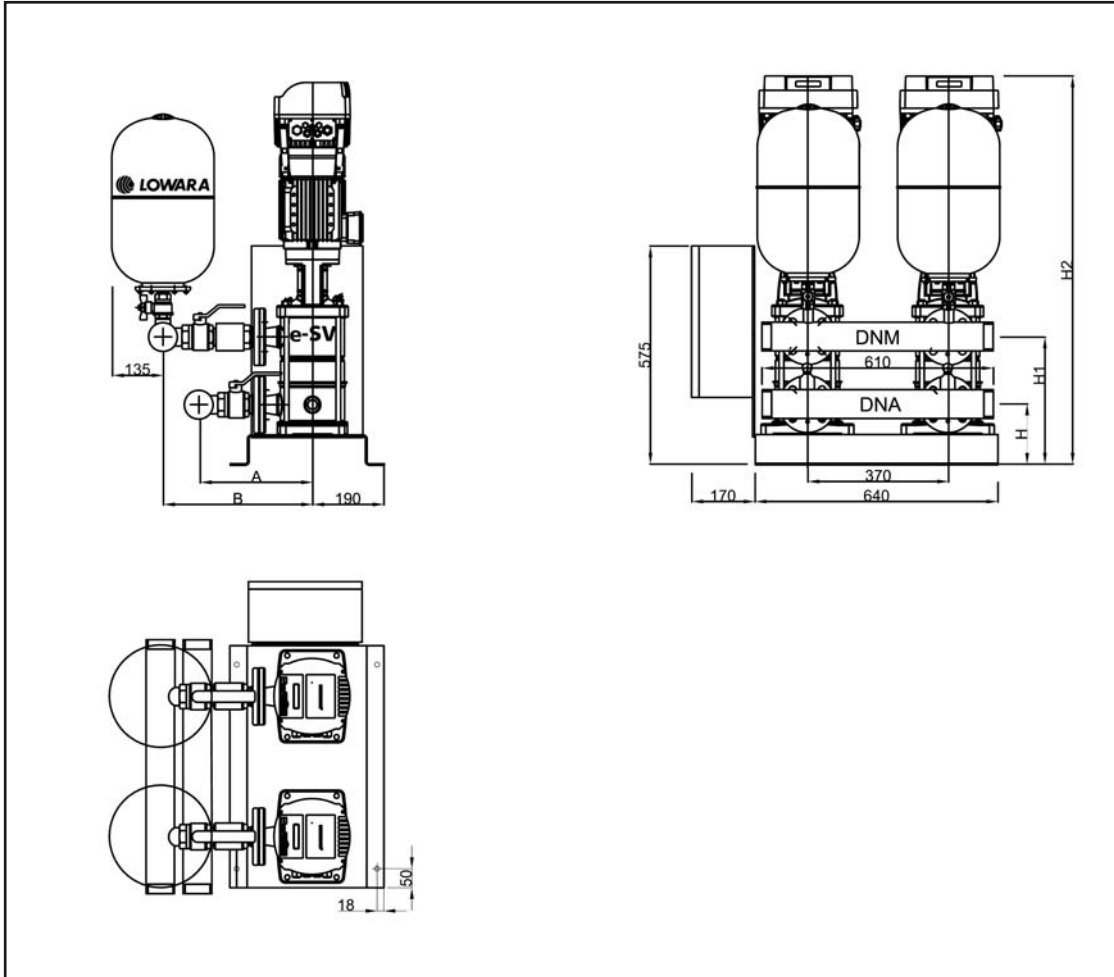

GHV20	DNA	DNM	A	B	H	H1	H2	kg
3SV07	R 2"	R 2"	257	375	155	287	765	145
3SV08	R 2"	R 2"	257	375	155	307	885	145
3SV09	R 2"	R 2"	257	375	155	327	905	150
3SV10	R 2"	R 2"	257	375	155	347	925	150
3SV11	R 2"	R 2"	257	375	155	367	945	150
3SV12	R 2"	R 2"	257	375	155	387	965	150
3SV13	R 2"	R 2"	257	375	155	407	1030	160
3SV14	R 2"	R 2"	257	375	155	427	1050	160
3SV16	R 2"	R 2"	257	375	155	447	1090	160
3SV19	R 2"	R 2"	257	375	155	527	1150	170
3SV21	R 2"	R 2"	257	375	155	547	1190	170

Dimensions in mm. Tolerance ± 10 mm.
Antivibration feet will add 25mm to the set height.

GHV20 SERIES 2 PUMP BOOSTER SETS DIMENSIONS, R VERSION

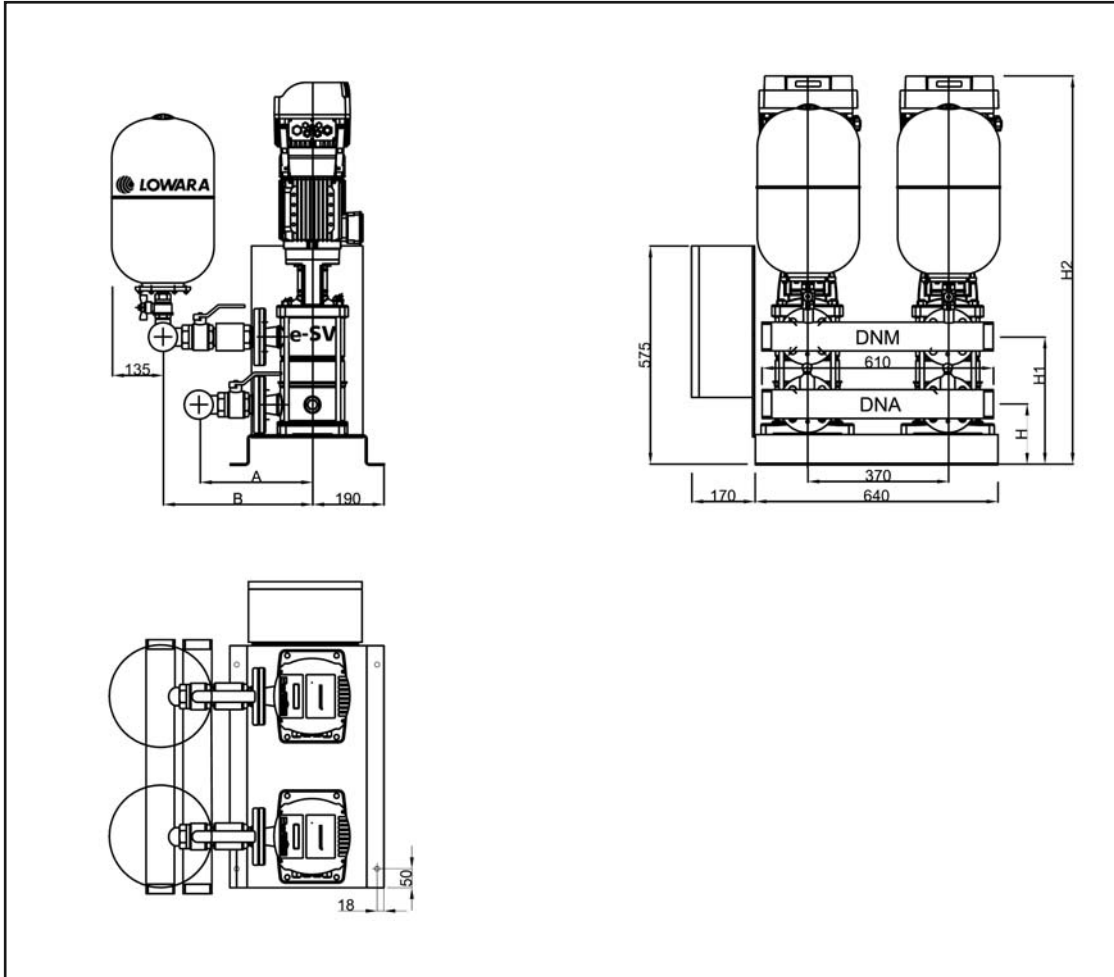

GHV20	DNA	DNM	A	B	H	H1	H2	kg
5SV07	R 2"	R 2"	265	383	155	322	900	155
5SV08	R 2"	R 2"	265	383	155	347	925	155
5SV09	R 2"	R 2"	265	383	155	372	995	170
5SV10	R 2"	R 2"	265	383	155	397	1020	170
5SV11	R 2"	R 2"	265	383	155	422	1045	170
5SV12	R 2"	R 2"	265	383	155	447	1070	190
5SV13	R 2"	R 2"	265	383	155	472	1095	190
5SV14	R 2"	R 2"	265	383	155	497	1120	190
5SV15	R 2"	R 2"	265	383	155	522	1145	190
5SV16	R 2"	R 2"	265	383	155	547	1170	190
5SV18	R 2"	R 2"	265	383	155	597	1230	200
5SV21	R 2"	R 2"	265	383	155	672	1305	200

Dimensions in mm. Tolerance ± 10 mm.
Antivibration feet will add 25mm to the set height.

GHV20 SERIES 2 PUMP BOOSTER SETS DIMENSIONS, R VERSION

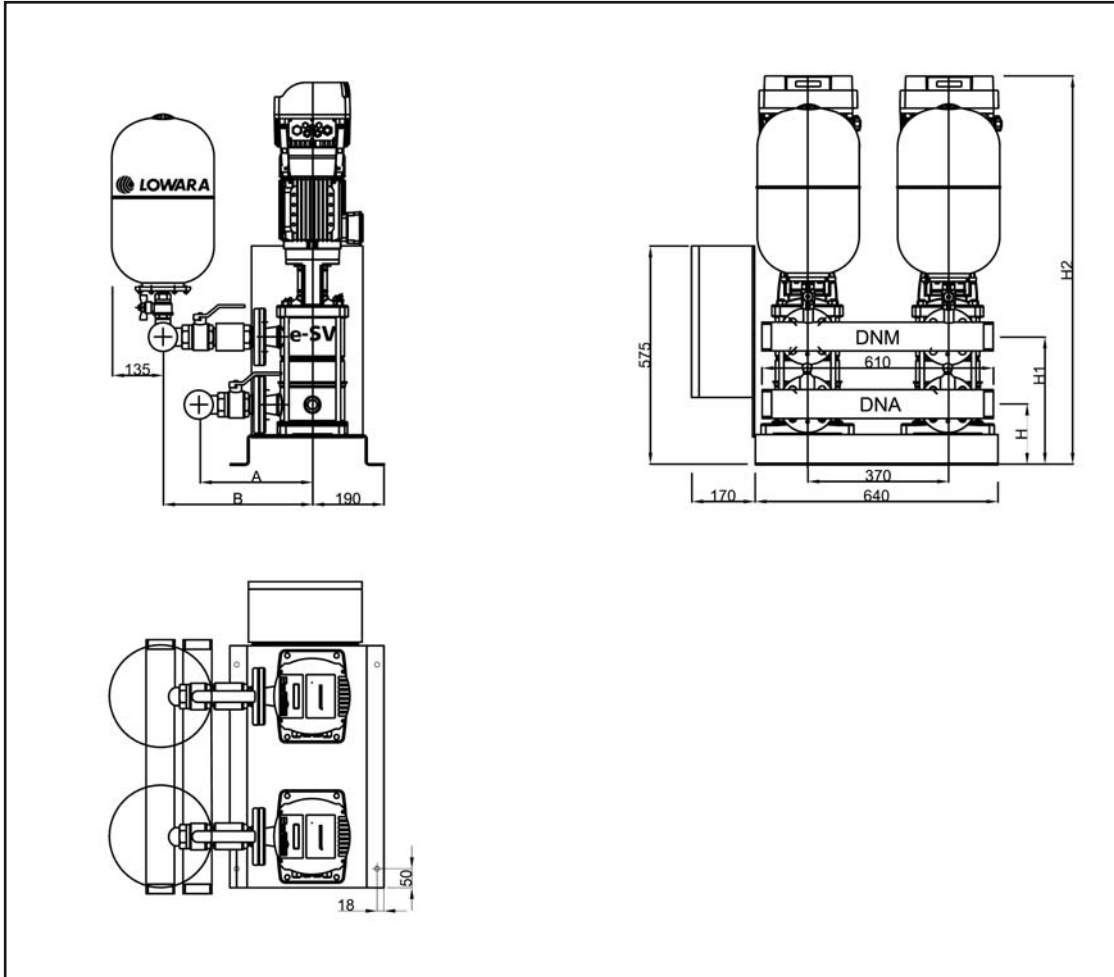

GHV20	DNA	DNM	A	B	H	H1	H2	kg
10SV05	R 2 1/2"	R 2 1/2"	297	392	160	339	995	209
10SV06	R 2 1/2"	R 2 1/2"	297	392	160	371	1027	214
10SV07	R 2 1/2"	R 2 1/2"	297	392	160	403	1069	218
10SV08	R 2 1/2"	R 2 1/2"	297	392	160	435	1101	223
10SV09	R 2 1/2"	R 2 1/2"	297	392	160	467	1124	223
10SV10	R 2 1/2"	R 2 1/2"	297	392	160	499	1156	227
10SV11	R 2 1/2"	R 2 1/2"	297	392	160	531	1218	230
10SV13	R 2 1/2"	R 2 1/2"	297	392	160	595	1405	232

Dimensions in mm. Tolerance ± 10 mm.
Antivibration feet will add 25mm to the set height.

GHV20 SERIES 2 PUMP BOOSTER SETS DIMENSIONS, R VERSION

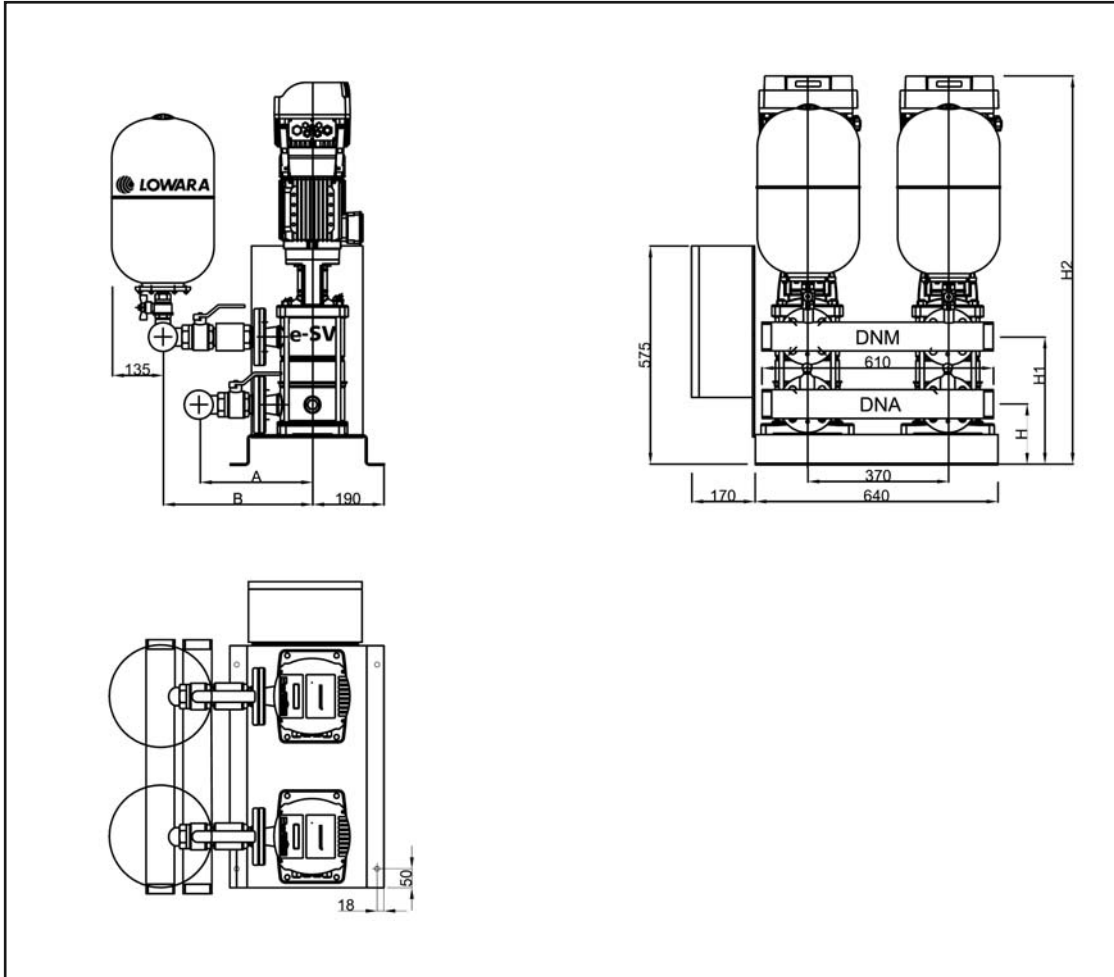

GHV20	DNA	DNM	A	B	H	H1	H2	kg
15SV04	R 3"	R 3"	341	470	170	381	1099	237
15SV05	R 3"	R 3"	341	470	170	429	1147	244
15SV06	R 3"	R 3"	341	470	170	477	1318	252
15SV07	R 3"	R 3"	341	470	170	525	1366	260
15SV08	R 3"	R 3"	341	470	170	573	1406	267
15SV09	R 3"	R 3"	341	470	170	621	1454	275

Dimensions in mm. Tolerance ± 10 mm.
Antivibration feet will add 25mm to the set height.

GHV20 SERIES 2 PUMP BOOSTER SETS DIMENSIONS, R VERSION

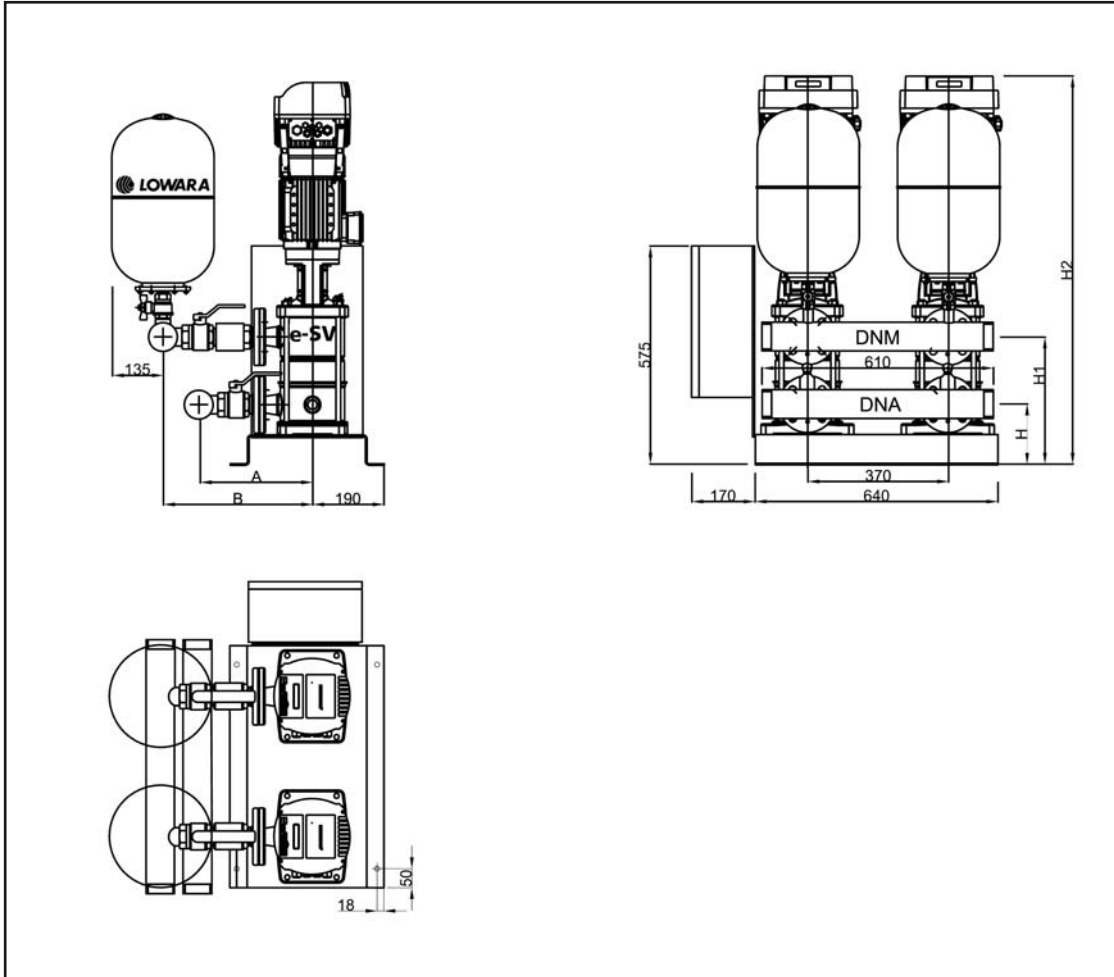

GHV20	DNA	DNM	A	B	H	H1	H2	kg
22SV04	R 3"	R 3"	341	470	170	381	1099	261
22SV05	R 3"	R 3"	341	470	170	429	1270	269
22SV06	R 3"	R 3"	341	470	170	477	1310	278
22SV07	R 3"	R 3"	341	470	170	525	1358	286

Dimensions in mm. Tolerance ± 10 mm.
Antivibration feet will add 25mm to the set height.

GHV20 SERIES 2 PUMP BOOSTER SETS DIMENSIONS, F VERSION

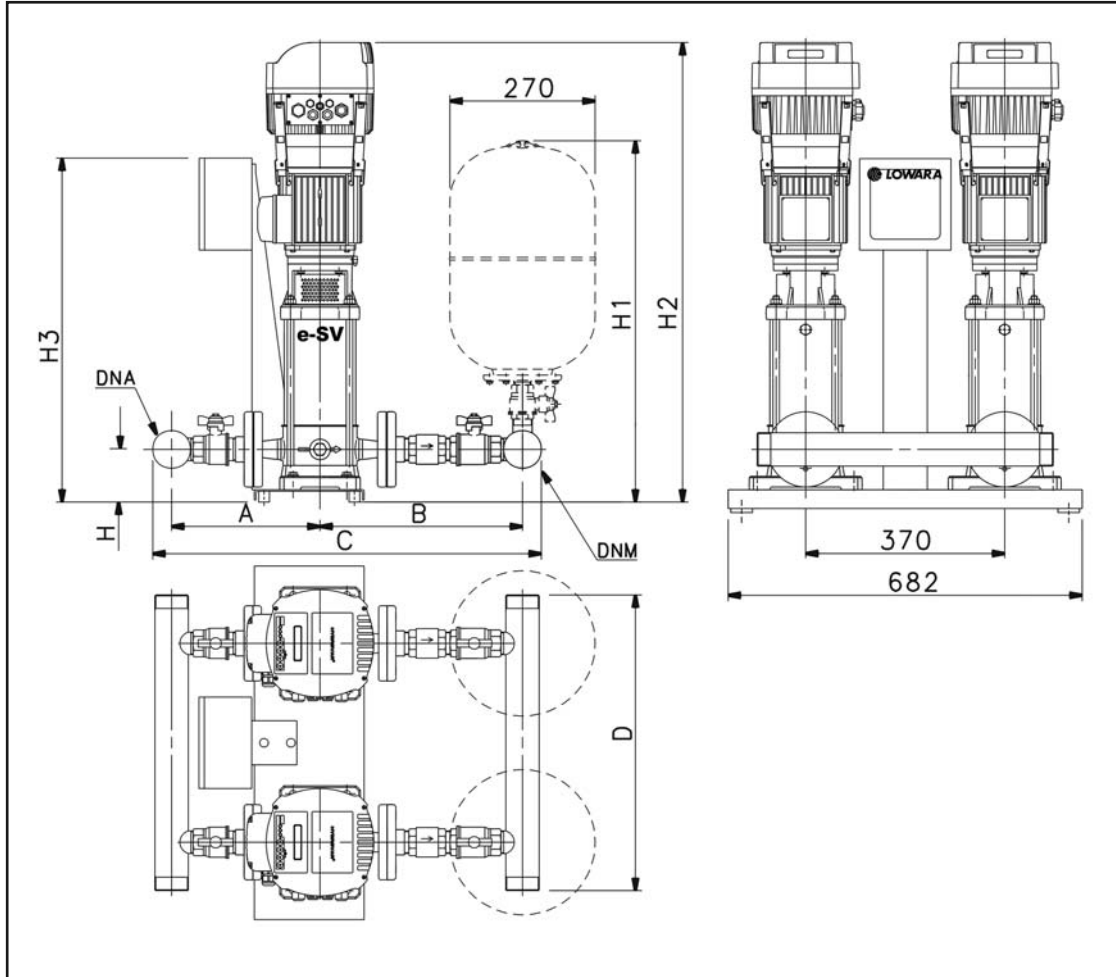

GHV20	DNA	DNM	A	B	C	D	H	H1	H2	H3	Kg
3SV05F005T/UK	R2"	R2"	252	304	616	610	109	765	753	700	130
3SV06F005T/UK	R2"	R2"	252	304	616	610	109	765	773	700	130
3SV07F007T/UK	R2"	R2"	252	304	616	610	109	765	835	700	135
3SV08F007T/UK	R2"	R2"	252	304	616	610	109	765	855	700	140
3SV09F011T/UK	R2"	R2"	252	304	616	610	109	765	875	700	140
3SV10F011T/UK	R2"	R2"	252	304	616	610	109	765	895	700	140
3SV11F011T/UK	R2"	R2"	252	304	616	610	109	765	915	700	140
3SV12F011T/UK	R2"	R2"	252	304	616	610	109	765	935	700	140
3SV13F015T/UK	R2"	R2"	252	304	616	610	109	765	965	700	150
3SV14F015T/UK	R2"	R2"	252	304	616	610	109	765	985	700	150
3SV16F015T/UK	R2"	R2"	252	304	616	610	109	765	1025	700	150
3SV19F022T/UK	R2"	R2"	252	304	616	610	109	765	1120	700	160
3SV21F022T/UK	R2"	R2"	252	304	616	610	109	765	1160	700	160

Dimensions in mm. Tolerance ± 10 mm.
Antivibration feet will add 25mm to the set height.

GHV20 SERIES 2 PUMP BOOSTER SETS DIMENSIONS, F VERSION

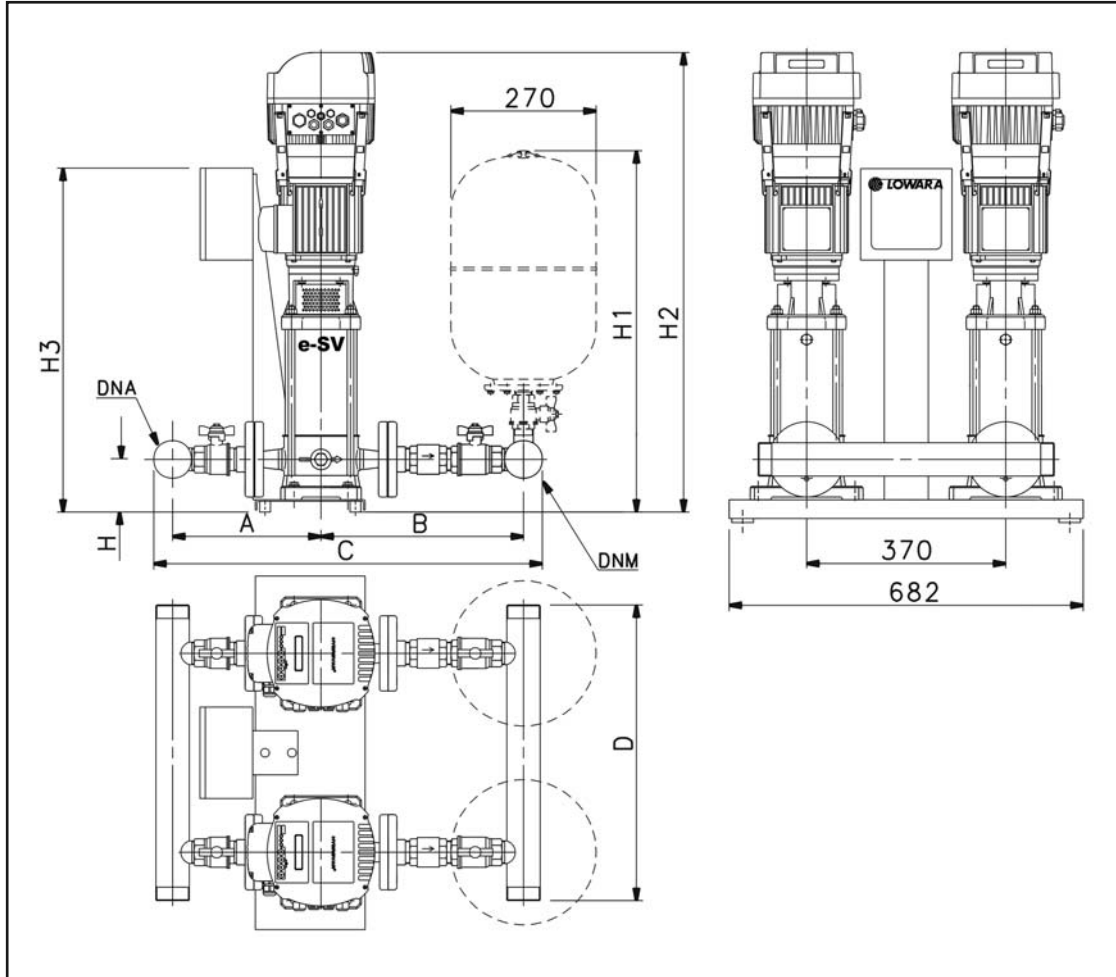

GHV20	DNA	DNM	A	B	C	D	H	H1	H2	H3	Kg
5SV03F005T/UK	R2"	R2"	265	327	652	610	109	765	728	700	135
5SV04F005T/UK	R2"	R2"	265	327	652	610	109	765	753	700	135
5SV05F007T/UK	R2"	R2"	265	327	652	610	109	765	820	700	145
5SV06F011T/UK	R2"	R2"	265	327	652	610	109	765	845	700	145
5SV07F011T/UK	R2"	R2"	265	327	652	610	109	765	870	700	145
5SV08011T/UK	R2"	R2"	265	327	652	610	109	765	895	700	145
5SV09F015T/UK	R2"	R2"	265	327	652	610	109	765	930	700	160
5SV10F015T/UK	R2"	R2"	265	327	652	610	109	765	955	700	160
5SV11F015T/UK	R2"	R2"	265	327	652	610	109	765	980	700	160
5SV12F022T/UK	R2"	R2"	265	327	652	610	109	765	1040	700	180
5SV13F022T/UK	R2"	R2"	265	327	652	610	109	765	1065	700	180
5SV14F022T/UK	R2"	R2"	265	327	652	610	109	765	1090	700	180
5SV16F022T/UK	R2"	R2"	265	327	652	610	109	765	1140	700	180
5SV18F030T/UK	R2"	R2"	265	327	652	610	109	765	1200	700	185
5SV21F030T/UK	R2"	R2"	265	327	652	610	109	765	1275	700	185

Dimensions in mm. Tolerance ± 10 mm.
Antivibration feet will add 25mm to the set height.

GHV20 SERIES 2 PUMP BOOSTER SETS DIMENSIONS, F VERSION

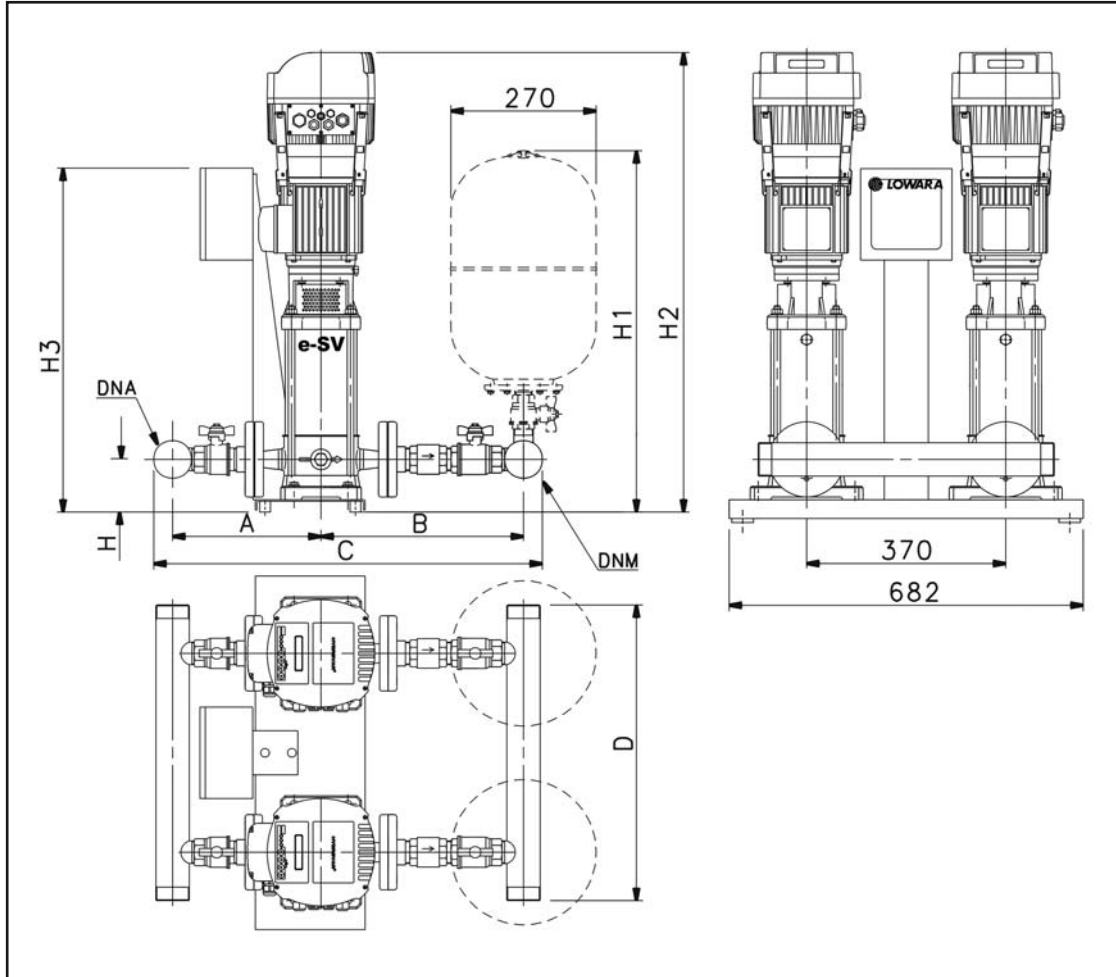

GHV20	DNA	DNM	A	B	C	D	H	H1	H2	H3	Kg
10SV02F007T/UK	R2 1/2"	R2 1/2"	297	362	735	610	114	770	824	700	186
10SV03F011T/UK	R2 1/2"	R2 1/2"	297	362	735	610	114	770	856	700	190
10SV04F015T/UK	R2 1/2"	R2 1/2"	297	362	735	610	114	770	898	700	195
10SV05F022T/UK	R2 1/2"	R2 1/2"	297	362	735	610	114	770	965	700	199
10SV06F022T/UK	R2 1/2"	R2 1/2"	297	362	735	610	114	770	997	700	204
10SV07F030T/UK	R2 1/2"	R2 1/2"	297	362	735	610	114	770	1039	700	208
10SV08F030T/UK	R2 1/2"	R2 1/2"	297	362	735	610	114	770	1069	700	210
10SV09F040T/UK	R2 1/2"	R2 1/2"	297	362	735	610	114	770	1121	700	213
10SV10F040T/UK	R2 1/2"	R2 1/2"	297	362	735	610	114	770	1153	700	217
10SV11F055T/UK	R2 1/2"	R2 1/2"	297	362	735	610	114	770	1185	700	222

Dimensions in mm. Tolerance ± 10 mm.
Antivibration feet will add 25mm to the set height.

GHV20 SERIES 2 PUMP BOOSTER SETS DIMENSIONS, F VERSION

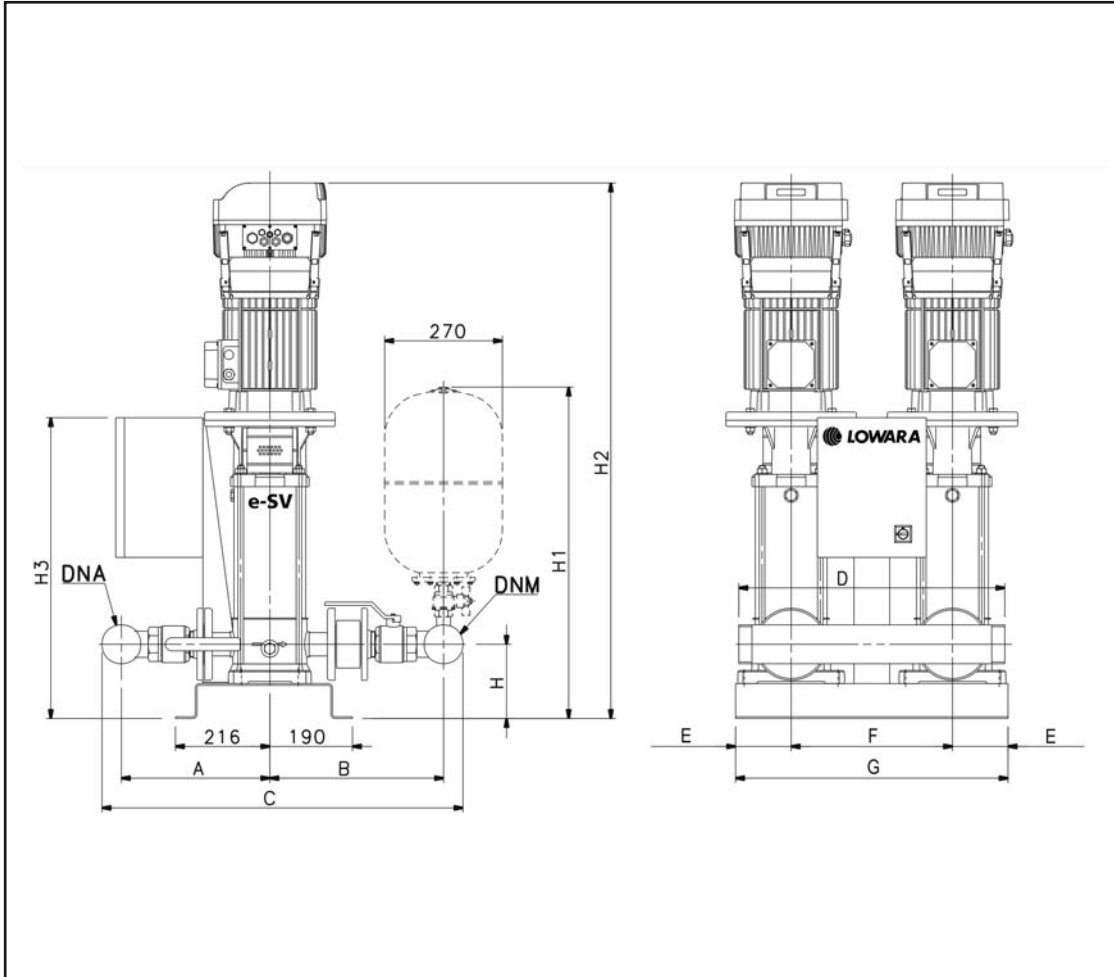

GHV20	DNA	DNM	A	B	C	D	E	F	G	H	H1	H2	H3	Kg
15SV03F030T/UK	R3"	R3"	342	399	829	610	135	370	640	170	780	1015	746	219
15SV04F040T/UK	R3"	R3"	342	399	829	610	135	370	640	170	780	1084	746	227
15SV05F040T/UK	R3"	R3"	342	399	829	610	135	370	640	170	780	1132	746	234
15SV06F055T/UK	R3"	R3"	342	399	829	610	135	370	640	170	780	1303	689	242
15SV07F055T/UK	R3"	R3"	342	399	829	610	135	370	640	170	780	1351	689	250
15SV08F075T/UK	R3"	R3"	342	399	829	610	135	370	640	170	780	1391	689	257
15SV09F075T/UK	R3"	R3"	342	399	829	610	135	370	640	170	780	1439	689	265
15SV10F110T/UK	R3"	R3"	342	399	829	680	260	440	960	200	795	1608	797	273

Dimensions in mm. Tolerance ± 10 mm.
Antivibration feet will add 25mm to the set height.

GHV20 SERIES 2 PUMP BOOSTER SETS DIMENSIONS, F VERSION

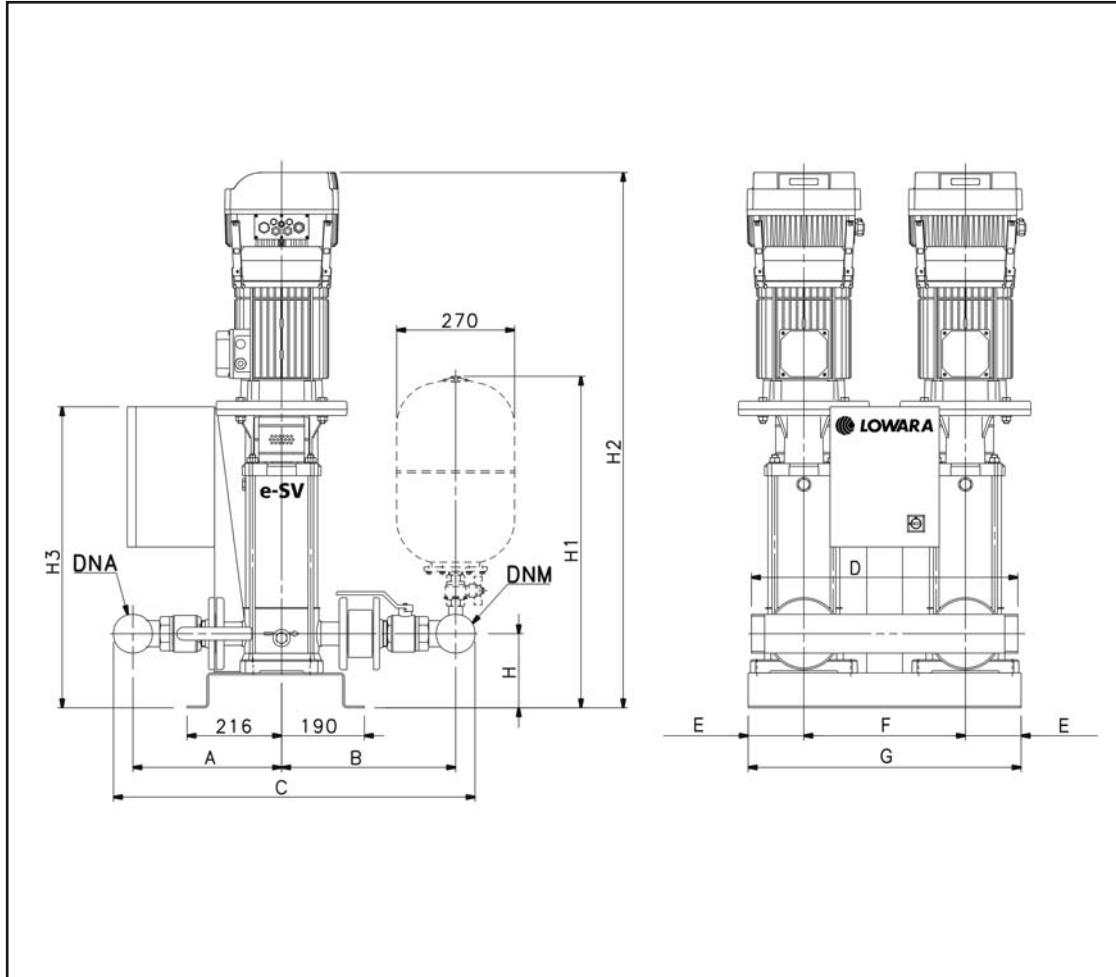

GHV20	DNA	DNM	A	B	C	D	E	F	G	H	H1	H2	H3	Kg
22SV02F022T/UK	R3"	R3"	399	342	829	610	135	370	640	180	780	957	746	233
22SV03F030T/UK	R3"	R3"	399	342	829	610	135	370	640	180	780	1015	746	242
22SV04F040T/UK	R3"	R3"	399	342	829	610	135	370	640	180	780	1084	746	250
22SV05F055T/UK	R3"	R3"	399	342	829	610	135	370	640	180	780	1255	689	259
22SV06F075T/UK	R3"	R3"	399	342	829	610	135	370	640	180	780	1295	689	267
22SV07F075T/UK	R3"	R3"	399	342	829	610	135	370	640	180	780	1343	689	276
22SV08F110T/UK	R3"	R3"	399	342	829	680	260	440	960	200	795	1512	797	301
22SV09F110T/UK	R3"	R3"	399	342	829	680	260	440	960	200	795	1560	797	301
22SV10F110T/UK	R3"	R3"	399	342	829	680	260	440	960	200	795	1608	797	301

Dimensions in mm. Tolerance ± 10 mm.
Antivibration feet will add 25mm to the set height.

GHV20 SERIES 2 PUMP BOOSTER SETS DIMENSIONS, F VERSION

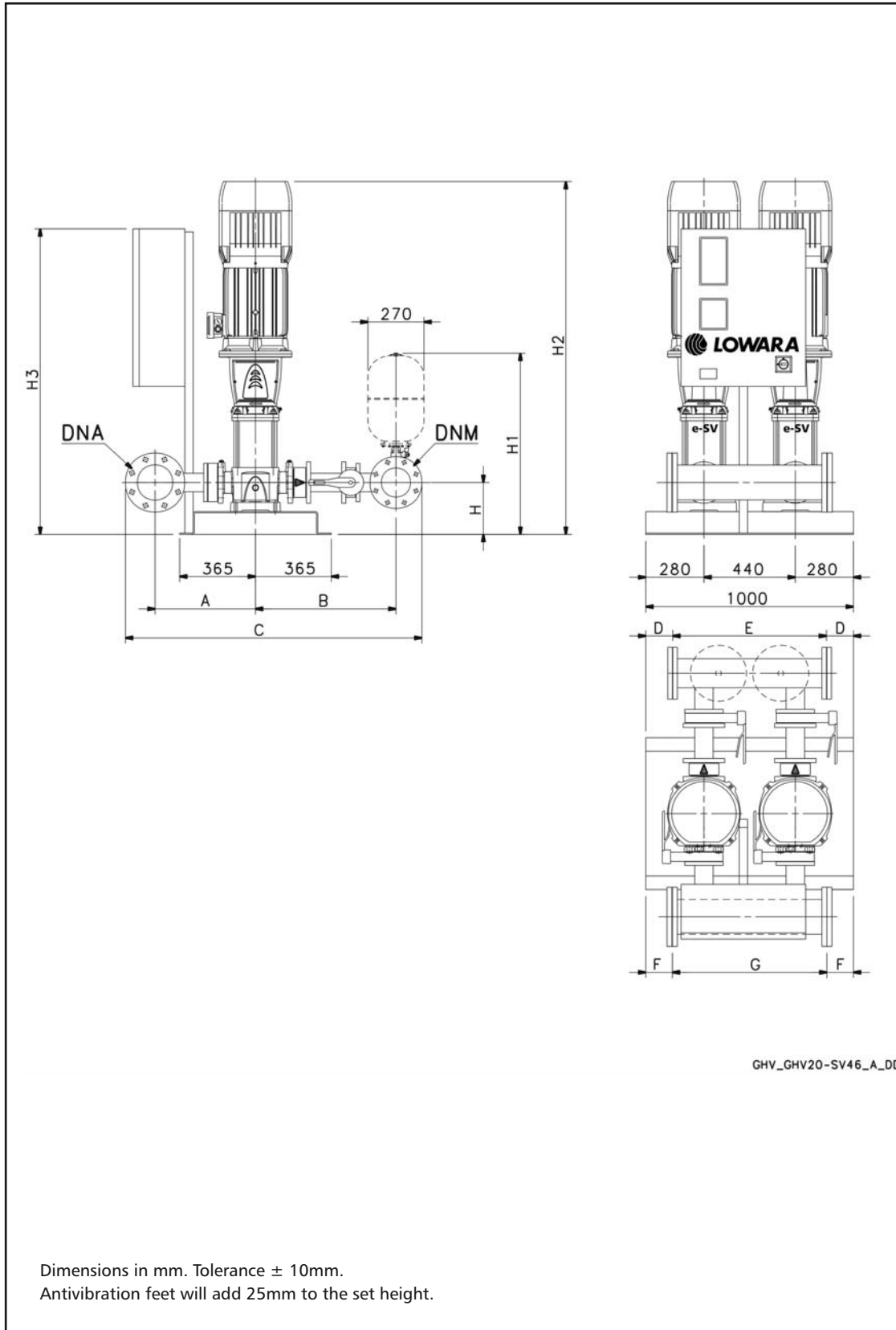

Dimensions in mm. Tolerance ± 10 mm.
Antivibration feet will add 25mm to the set height.

GHV20 SERIES 2 PUMP BOOSTER SETS DIMENSIONS, F VERSION

GHV 20	DNA	DNM	A	B	C	D	E	F	G	H	H1	H2	H3	kg
33SV1/1AG022T	100	80	448	701	1359	90	780	90	780	215	810	1032	886	560
33SV1G030T	100	80	448	701	1359	90	780	90	780	215	810	1067	1017	560
33SV2/2AG040T	100	80	448	701	1359	90	780	90	780	215	810	1163	1017	560
33SV2/1AG040T	100	80	448	701	1359	90	780	90	780	215	810	1163	1017	560
33SV2G055T	100	80	448	701	1359	90	780	90	780	215	810	1239	1017	560
33SV3/2AG055T	100	80	448	701	1359	90	780	90	780	215	810	1314	1017	560
33SV3/1AG075T	100	80	448	701	1359	90	780	90	780	215	810	1306	1017	560
33SV3G075T	100	80	448	701	1359	90	780	90	780	215	810	1306	1017	560
33SV4/2AG075T	100	80	448	701	1359	90	780	90	780	215	810	1381	1017	560
33SV4/1AG110T	100	80	448	701	1359	90	780	90	780	215	810	1477	1017	560
33SV4G110T	100	80	448	701	1359	90	780	90	780	215	810	1477	1017	560
33SV5/2AG110T	100	80	448	701	1359	90	780	90	780	215	810	1552	1017	560
33SV5/1AG110T	100	80	448	701	1359	90	780	90	780	215	810	1552	1017	560
33SV5G150T	100	80	448	701	1359	90	780	90	780	215	810	1656	1017	560
33SV6/2AG150T	100	80	448	701	1359	90	780	90	780	215	810	1731	1017	560
33SV6/1AG150T	100	80	448	701	1359	90	780	90	780	215	810	1731	1017	560
33SV6G150T	100	80	448	701	1359	90	780	90	780	215	810	1731	1017	560
33SV7/2AG150T	100	80	448	701	1359	90	780	90	780	215	810	1806	1017	560
46SV1/1AG030T	125	100	484	739	1457	90	780	90	780	250	857	1107	1017	720
46SV1G040T	125	100	484	739	1457	90	780	90	780	250	857	1128	1017	720
46SV2/2AG055T	125	100	484	739	1457	90	780	90	780	250	857	1279	1017	720
46SV2G075T	125	100	484	739	1457	90	780	90	780	250	857	1271	1017	720
46SV3/2AG110T	125	100	484	739	1457	90	780	90	780	250	857	1442	1017	720
46SV3G110T	125	100	484	739	1457	90	780	90	780	250	857	1442	1017	720
46SV4/2AG150T	125	100	484	739	1457	90	780	90	780	250	857	1621	1017	720
46SV4G150T	125	100	484	739	1457	90	780	90	780	250	857	1621	1017	720
46SV5/2AG185T	125	100	484	739	1457	90	780	90	780	250	857	1696	1194	720
46SV5G185T	125	100	484	739	1457	90	780	90	780	250	857	1696	1194	720
46SV6/2AG220T	125	100	484	739	1457	90	780	90	780	250	857	1771	1194	720
46SV6G220T	125	100	484	739	1457	90	780	90	780	250	857	1771	1194	720
66SV1/1AG040T	150	125	504	780	1551	90	780	70	820	250	870	1153	1017	860
66SV1G055T	150	125	504	780	1551	90	780	70	820	250	870	1229	1017	860
66SV2/2AG075T	150	125	504	780	1551	90	780	70	820	250	870	1311	1017	860
66SV2/1AG110T	150	125	504	780	1551	90	780	70	820	250	870	1407	1017	860
66SV2G110T	150	125	504	780	1551	90	780	70	820	250	870	1407	1017	860
66SV3/2AG150T	150	125	504	780	1551	90	780	70	820	250	870	1601	1017	860
66SV3/1AG150T	150	125	504	780	1551	90	780	70	820	250	870	1601	1017	860
66SV3G185T	150	125	504	780	1551	90	780	70	820	250	870	1601	1194	860
66SV4/2AG185T	150	125	504	780	1551	90	780	70	820	250	870	1691	1194	860
66SV4/1AG220T	150	125	504	780	1551	90	780	70	820	250	870	1691	1194	860
66SV4G220T	150	125	504	780	1551	90	780	70	820	250	870	1691	1194	860
92SV1/1AG055T	200	150	529	794	1635	70	820	70	820	250	884	1229	1237	860
92SV1G075T	200	150	529	794	1635	70	820	70	820	250	884	1221	1237	860
92SV2/2AG110T	200	150	529	794	1635	70	820	70	820	250	884	1407	1237	860
92SV2G150T	200	150	529	794	1635	70	820	70	820	250	884	1511	1237	860
92SV3/2AG185T	200	150	529	794	1635	70	820	70	820	250	884	1601	1194	860
92SV3G220T	200	150	529	794	1635	70	820	70	820	250	884	1601	1194	860

GHV30 SERIES 3 PUMP BOOSTER SETS DIMENSIONS, R VERSION

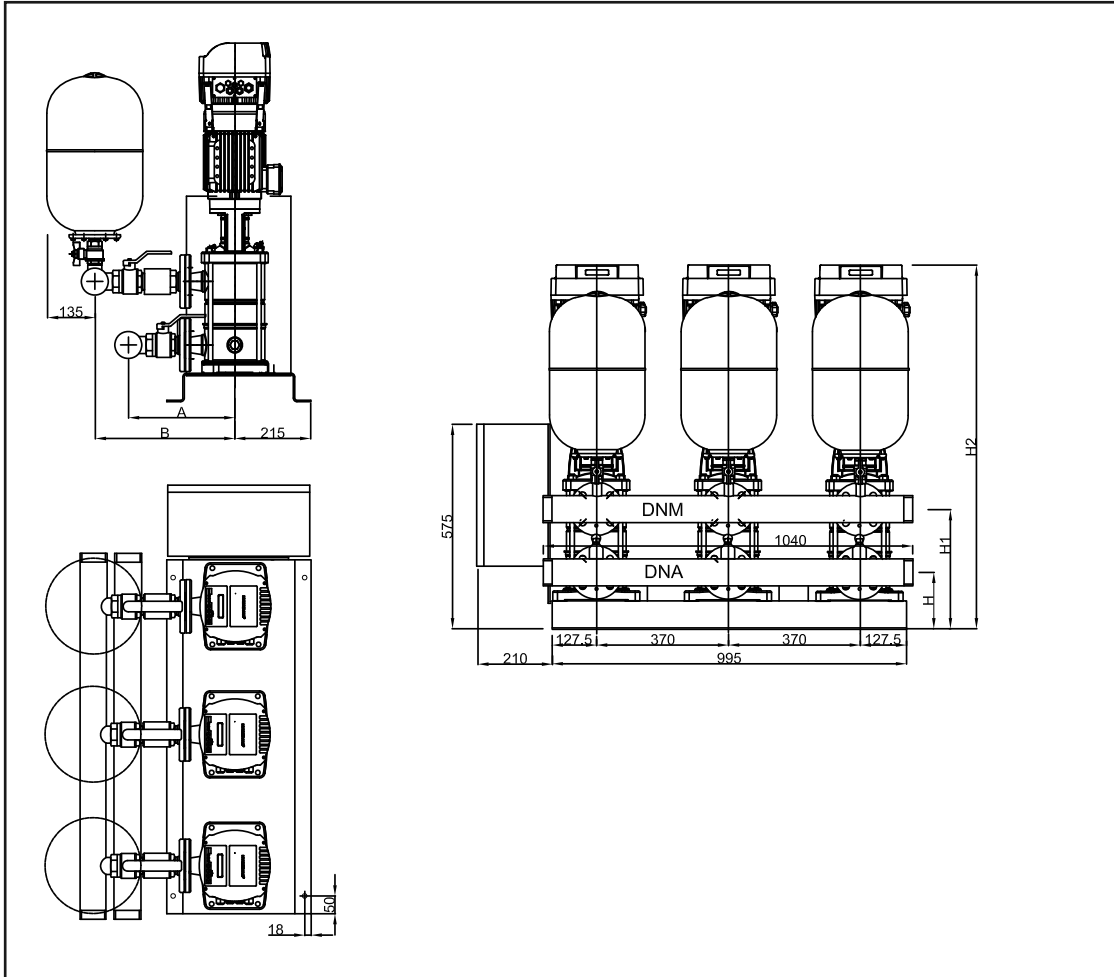

GHV30	DNA	DNM	A	B	H	H1	H2	kg
3SV07	R 2"	R 2"	257	375	155	287	765	207
3SV08	R 2"	R 2"	257	375	155	307	885	214
3SV09	R 2"	R 2"	257	375	155	327	905	214
3SV10	R 2"	R 2"	257	375	155	347	925	214
3SV11	R 2"	R 2"	257	375	155	367	945	214
3SV12	R 2"	R 2"	257	375	155	387	965	214
3SV13	R 2"	R 2"	257	375	155	407	1030	228
3SV14	R 2"	R 2"	257	375	155	427	1050	228
3SV16	R 2"	R 2"	257	375	155	447	1090	228
3SV19	R 2"	R 2"	257	375	155	527	1150	243
3SV21	R 2"	R 2"	257	375	155	547	1190	243

Dimensions in mm. Tolerance ± 10 mm.
Antivibration feet will add 25mm to the set height.

GHV30 SERIES 3 PUMP BOOSTER SETS DIMENSIONS, R VERSION

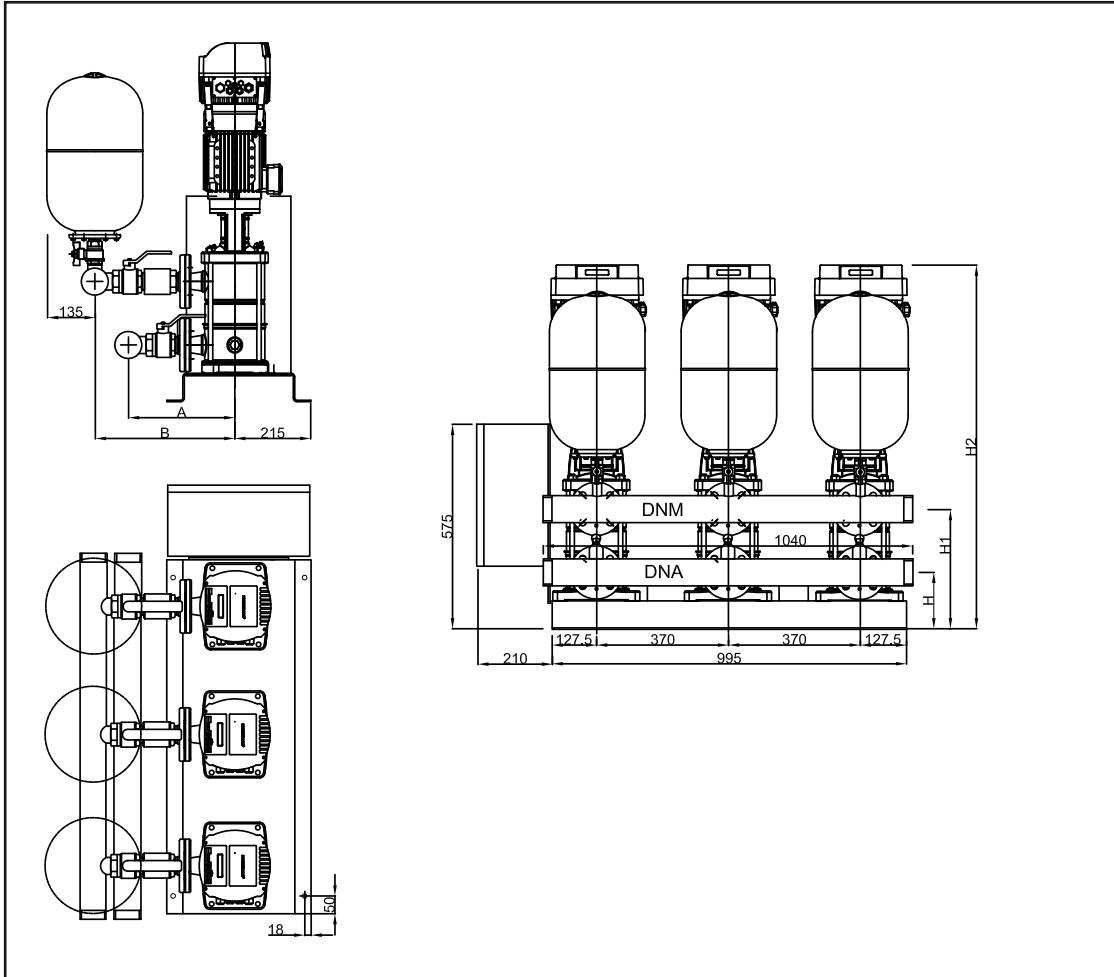

GHV30	DNA	DNM	A	B	H	H1	H2	kg
5SV07	R 2"	R 2"	265	383	155	322	900	217
5SV08	R 2"	R 2"	265	383	155	347	925	217
5SV09	R 2"	R 2"	265	383	155	372	995	238
5SV10	R 2"	R 2"	265	383	155	397	1020	238
5SV11	R 2"	R 2"	265	383	155	422	1045	238
5SV12	R 2"	R 2"	265	383	155	447	1070	267
5SV13	R 2"	R 2"	265	383	155	472	1095	267
5SV14	R 2"	R 2"	265	383	155	497	1120	267
5SV15	R 2"	R 2"	265	383	155	522	1145	267
5SV16	R 2"	R 2"	265	383	155	547	1170	267
5SV18	R 2"	R 2"	265	383	155	597	1230	280
5SV21	R 2"	R 2"	265	383	155	672	1305	280

Dimensions in mm. Tolerance ± 10 mm.
Antivibration feet will add 25mm to the set height.

GHV30 SERIES 3 PUMP BOOSTER SETS DIMENSIONS, R VERSION

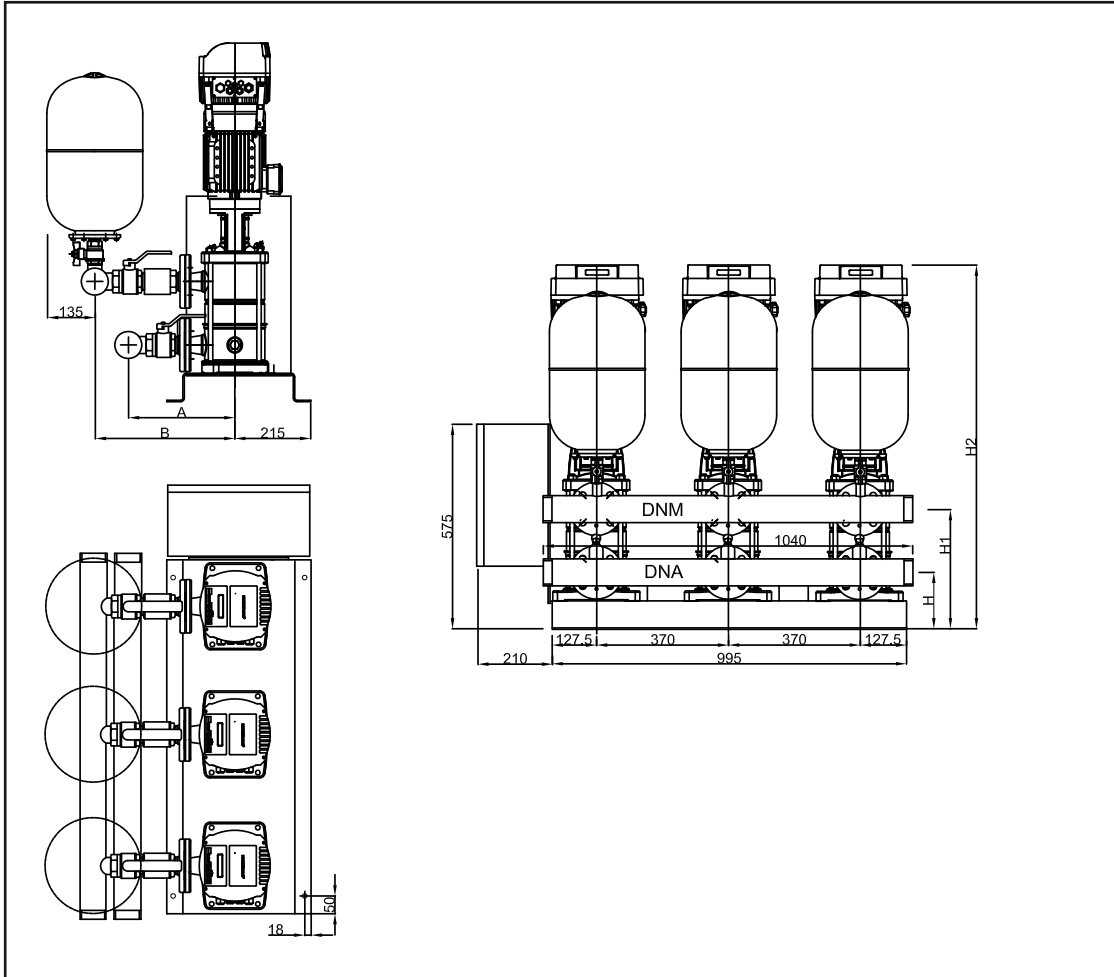

GHV30	DNA	DNM	A	B	H	H1	H2	kg
10SV05	R 2 1/2"	R 2 1/2"	297	392	160	339	995	324
10SV06	R 2 1/2"	R 2 1/2"	297	392	160	371	1027	331
10SV07	R 2 1/2"	R 2 1/2"	297	392	160	403	1069	338
10SV08	R 2 1/2"	R 2 1/2"	297	392	160	435	1101	345
10SV09	R 2 1/2"	R 2 1/2"	297	392	160	467	1124	345
10SV10	R 2 1/2"	R 2 1/2"	297	392	160	499	1156	352
10SV11	R 2 1/2"	R 2 1/2"	297	392	160	531	1218	360
10SV13	R 2 1/2"	R 2 1/2"	297	392	160	595	1405	360

Dimensions in mm. Tolerance ± 10 mm.
Antivibration feet will add 25mm to the set height.

GHV30 SERIES 3 PUMP BOOSTER SETS DIMENSIONS, R VERSION

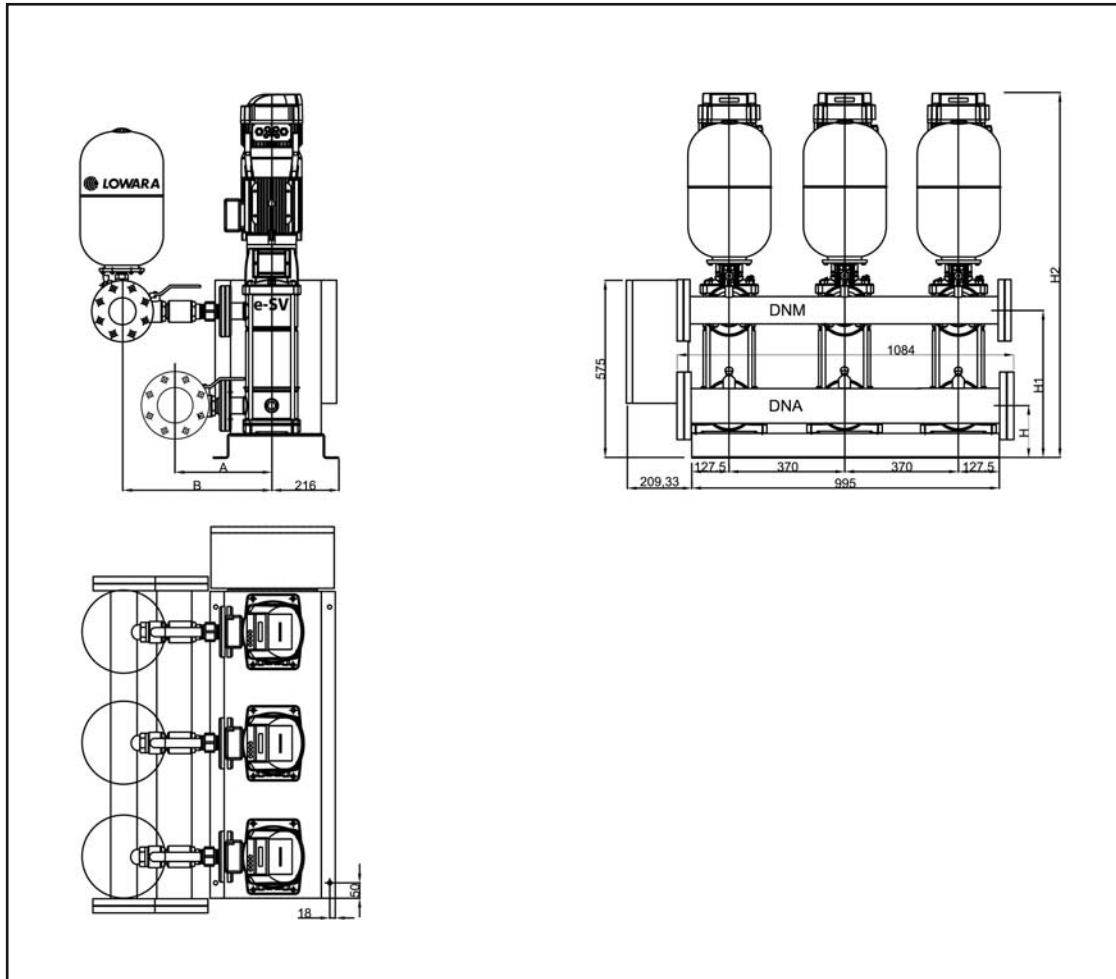

GHV30	DNA	DNM	A	B	H	H1	H2	kg
15SV04	100	80	341	470	170	381	1099	328
15SV05	100	80	341	470	170	429	1147	338
15SV06	100	80	341	470	170	477	1318	349
15SV07	100	80	341	470	170	525	1366	360
15SV08	100	80	341	470	170	573	1406	370
15SV09	100	80	341	470	170	621	1454	381

Dimensions in mm. Tolerance ± 10 mm.
Antivibration feet will add 25mm to the set height.

GHV30 SERIES 3 PUMP BOOSTER SETS DIMENSIONS, R VERSION

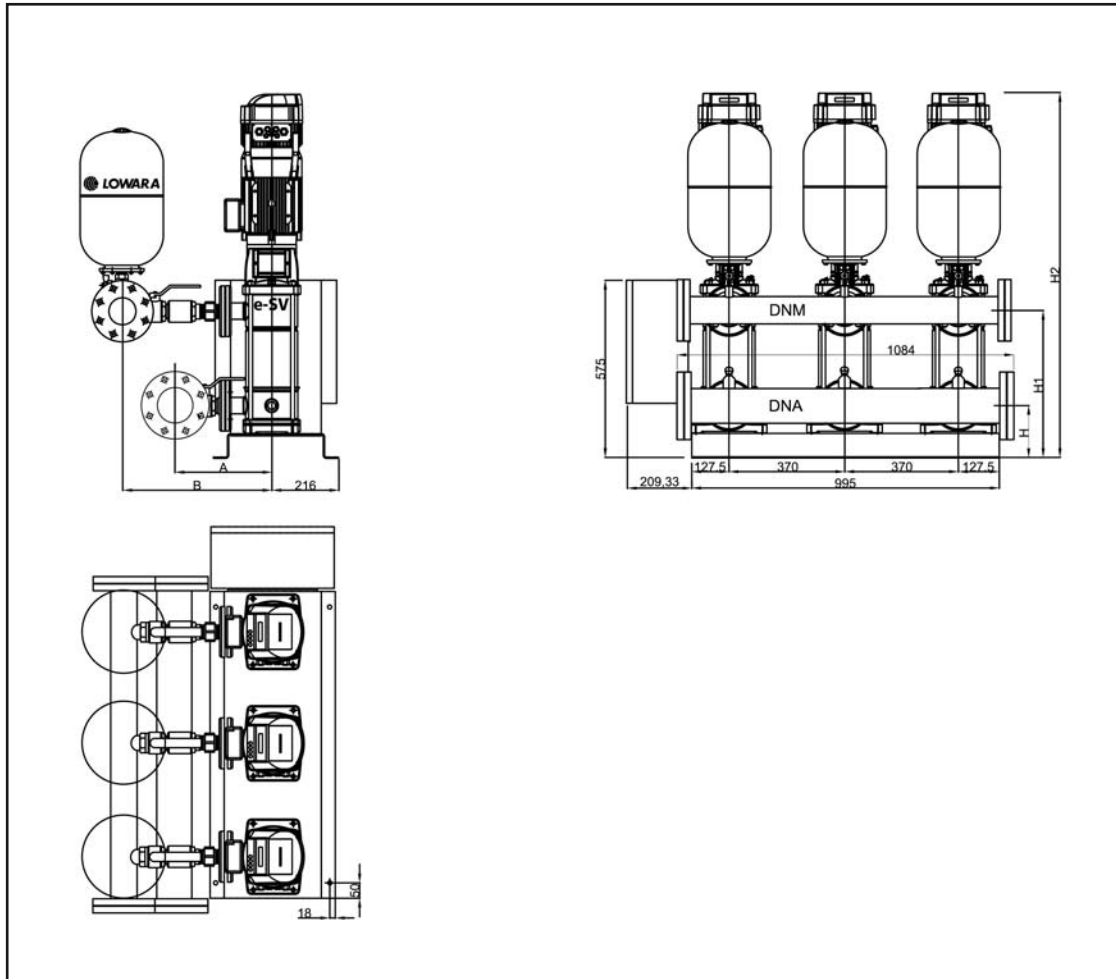

GHV30	DNA	DNM	A	B	H	H1	H2	kg
22SV04	100	100	341	470	170	381	1099	344
22SV05	100	100	341	470	170	429	1270	355
22SV06	100	100	341	470	170	477	1310	366
22SV07	100	100	341	470	170	525	1358	378

Dimensions in mm. Tolerance ± 10 mm.
Antivibration feet will add 25mm to the set height.

GHV30 SERIES 3 PUMP BOOSTER SETS DIMENSIONS, F VERSION

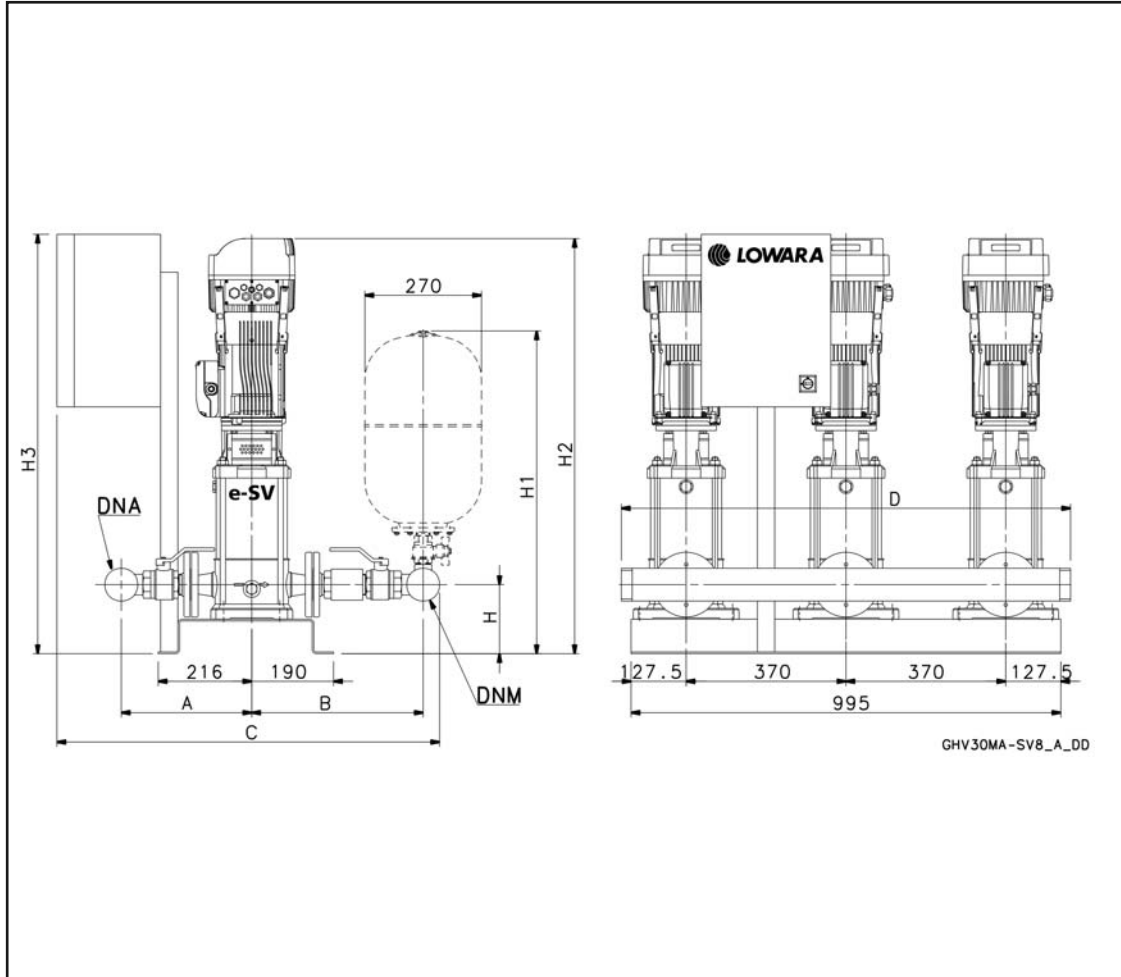

GHV30	DNA	DNM	A	B	C	D	H	H1	H2	H3	kg
3SV05F005T	R 2"	R 2"	252	321	733	1040	155	765	799	846	186
3SV06F005T	R 2"	R 2"	252	321	733	1040	155	765	819	846	186
3SV07F007T	R 2"	R 2"	252	321	733	1040	155	765	881	846	193
3SV08F007T	R 2"	R 2"	252	321	733	1040	155	765	901	846	200
3SV09F011T	R 2"	R 2"	252	321	733	1040	155	765	921	846	200
3SV10F011T	R 2"	R 2"	252	321	733	1040	155	765	941	846	200
3SV12F011T	R 2"	R 2"	252	321	733	1040	155	765	981	846	200
3SV13F015T	R 2"	R 2"	252	321	733	1040	155	765	1016	846	214
3SV16F015T	R 2"	R 2"	252	321	733	1040	155	765	1076	846	214
3SV19F022T	R 2"	R 2"	252	321	733	1040	155	765	1136	846	228
3SV21F022T	R 2"	R 2"	252	321	733	1040	155	765	1176	846	228

Dimensions in mm. Tolerance ± 10 mm.
Antivibration feet will add 25mm to the set height.

GHV30 SERIES 3 PUMP BOOSTER SETS DIMENSIONS, F VERSION

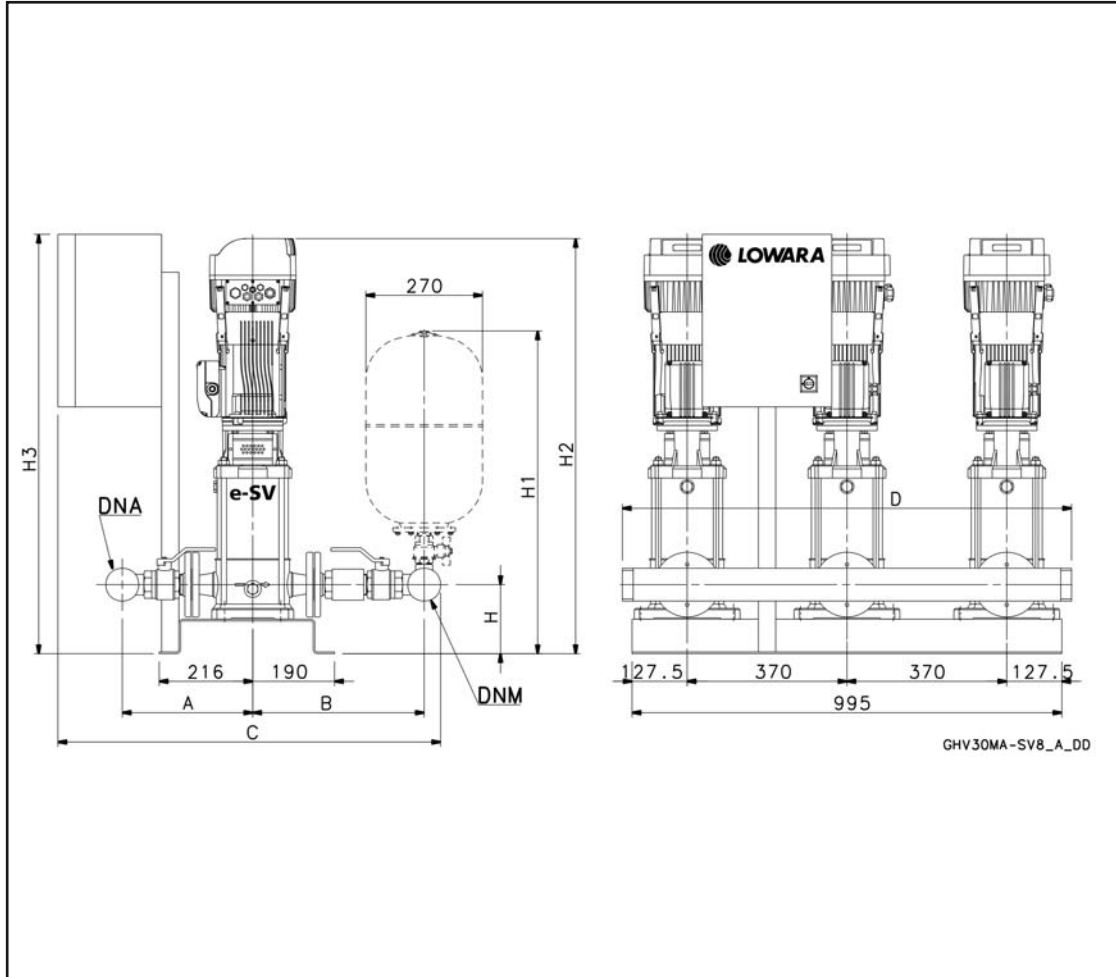

GHV30	DNA	DNM	A	B	C	D	H	H1	H2	H3	kg
5SV03F005T	R 2"	R 2"	265	328	733	1040	155	765	774	846	193
5SV04F005T	R 2"	R 2"	265	328	733	1040	155	765	799	846	193
5SV05F007T	R 2"	R 2"	265	328	733	1040	155	765	866	846	207
5SV06F011T	R 2"	R 2"	265	328	733	1040	155	765	891	846	207
5SV07F11T	R 2"	R 2"	265	328	733	1040	155	765	916	846	207
5SV08F011T	R 2"	R 2"	265	328	733	1040	155	765	941	846	207
5SV09F015T	R 2"	R 2"	265	328	733	1040	155	765	981	846	228
5SV11F015T	R 2"	R 2"	265	328	733	1040	155	765	1031	846	228
5SV12F022T	R 2"	R 2"	265	328	733	1040	155	765	1056	846	257
5SV13F022T	R 2"	R 2"	265	328	733	1040	155	765	1081	846	257
5SV14F022T	R 2"	R 2"	265	328	733	1040	155	765	1106	846	257
5SV16F022T	R 2"	R 2"	265	328	733	1040	155	765	1156	846	257
5SV18F030T	R 2"	R 2"	265	328	733	1040	155	765	1236	846	262
5SV21F030T	R 2"	R 2"	265	328	733	1040	155	765	1311	846	262

Dimensions in mm. Tolerance ± 10 mm.

Antivibration feet will add 25mm to the set height.

GHV30 SERIES 3 PUMP BOOSTER SETS DIMENSIONS, F VERSION

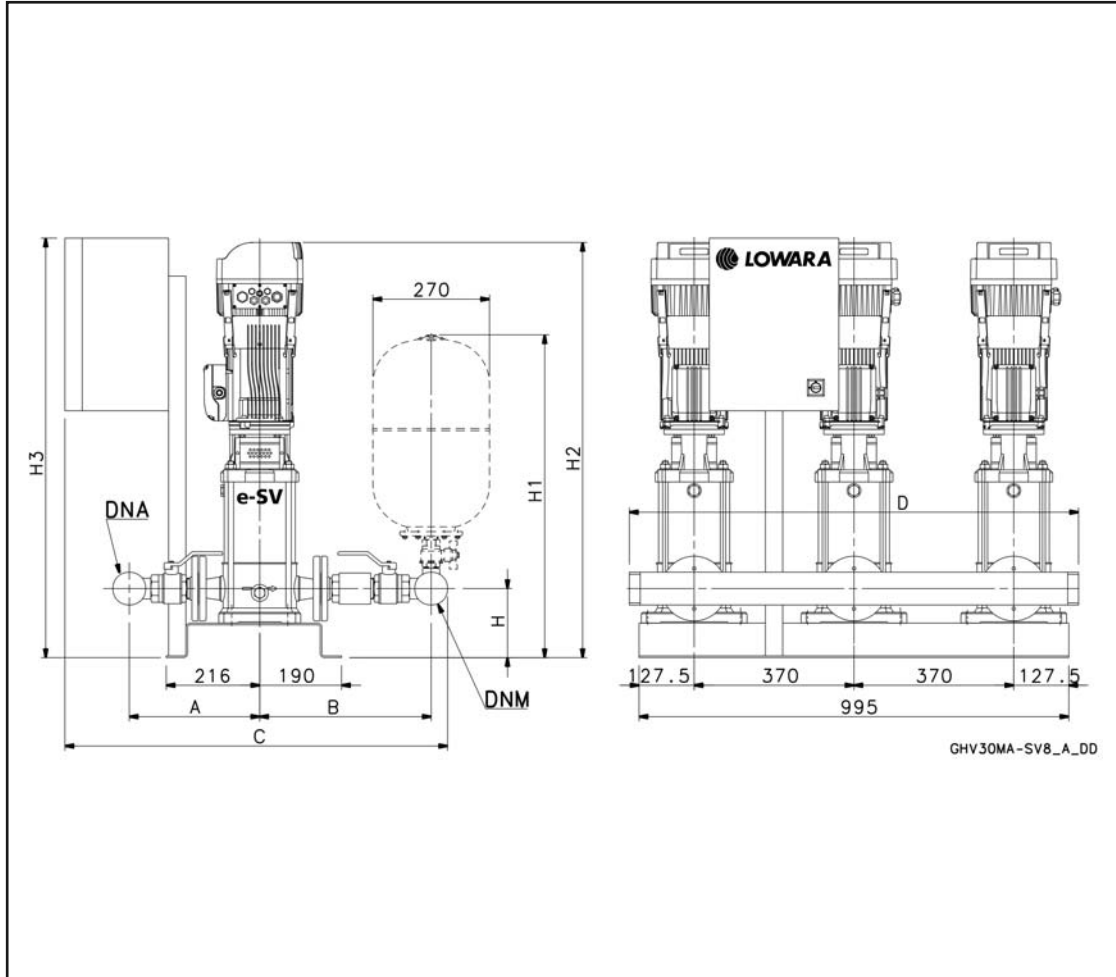

GHV30	DNA	DNM	A	B	C	D	H	H1	H2	H3	kg
10SV04F015T	R 2 1/2"	R 2 1/2"	297	362	735	1040	160	770	979	846	307
10SV05F022T	R 2 1/2"	R 2 1/2"	297	362	735	1040	160	770	1011	846	314
10SV06F022T	R 2 1/2"	R 2 1/2"	297	362	735	1040	160	770	1043	846	321
10SV07F030T	R 2 1/2"	R 2 1/2"	297	362	735	1040	160	770	1085	846	328
10SV09F040T	R 2 1/2"	R 2 1/2"	297	362	735	1040	160	770	1170	846	335
10SV10F040T	R 2 1/2"	R 2 1/2"	297	362	735	1040	160	770	1202	846	342
10SV13F055T	R 2 1/2"	R 2 1/2"	297	362	735	1040	160	770	1421	846	350

Dimensions in mm. Tolerance ± 10 mm.
Antivibration feet will add 25mm to the set height.

GHV30 SERIES 3 PUMP BOOSTER SETS DIMENSIONS, F VERSION

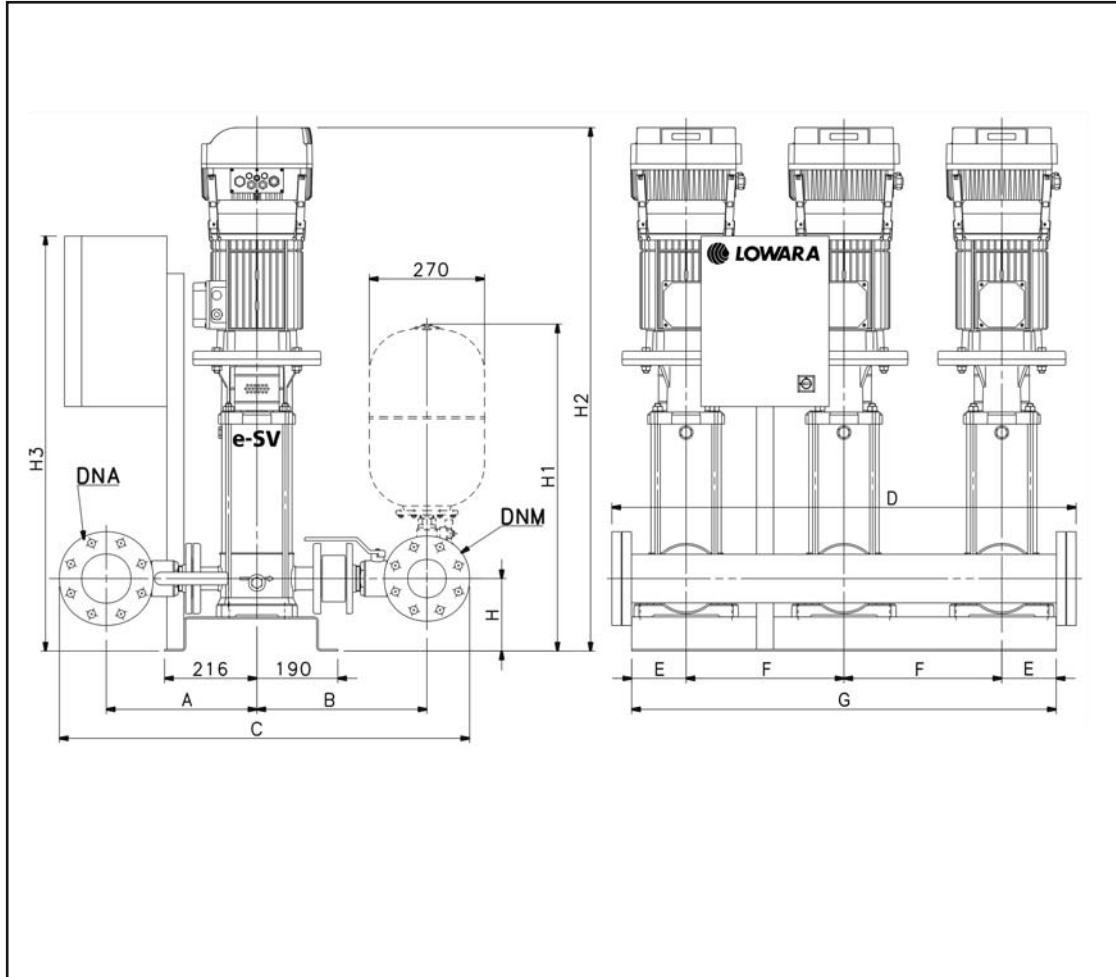

GHV30	DNA	DNM	A	B	C	D	E	F	G	H	H1	H2	H3	kg
15SV03F030T	100	80	354	399	963	1084	128	370	996	170	780	1015	846	307
15SV04F040T	100	80	354	399	963	1084	128	370	996	170	780	1608	846	318
15SV05F040T	100	80	354	399	963	1084	128	370	996	170	780	1132	846	328
15SV06F055T	100	80	354	399	963	1084	128	370	996	170	780	1303	846	339
15SV07F055T	100	80	354	399	963	1084	128	370	996	170	780	1351	846	350
15SV08F075T	100	80	354	399	963	1084	128	370	996	170	780	1391	846	360
15SV09F075T	100	80	354	399	963	1084	128	370	996	170	780	1439	846	371
15SV10F110T	100	80	354	399	963	1084	260	440	1400	170	795	1578	973	382

Dimensions in mm. Tolerance ± 10 mm.
Antivibration feet will add 25mm to the set height.

GHV30 SERIES 3 PUMP BOOSTER SETS DIMENSIONS, F VERSION

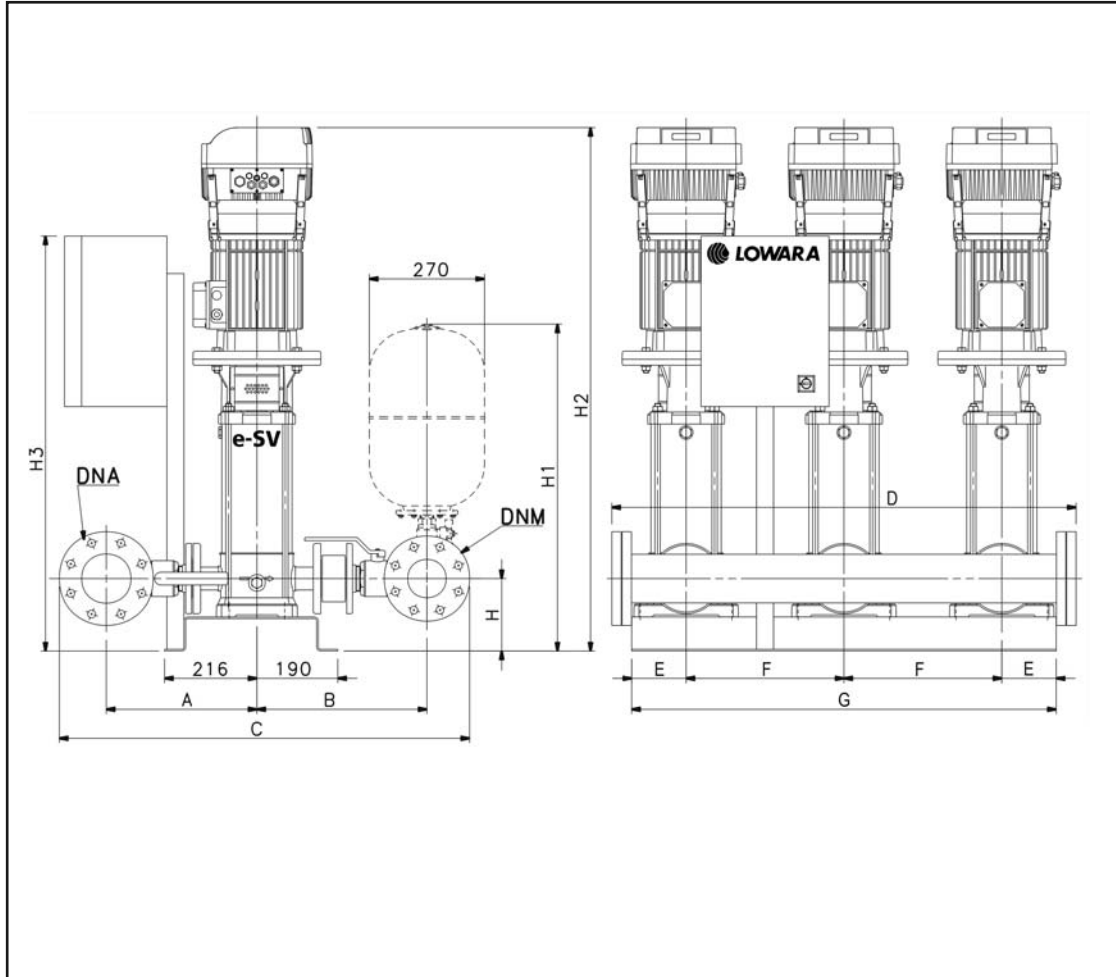

GHV30	DNA	DNM	A	B	C	D	E	F	G	H	H1	H2	H3	kg
22SV02F022T	100	100	354	411	985	1084	128	370	996	170	780	957	846	311
22SV03F030T	100	100	354	411	985	1084	128	370	996	170	780	1015	846	323
22SV04F040T	100	100	354	411	985	1084	128	370	996	170	780	1084	846	334
22SV05F055T	100	100	354	411	985	1084	128	370	996	170	780	1255	846	345
22SV06F075T	100	100	354	411	985	1084	128	370	996	170	780	1295	846	356
22SV07F075T	100	100	354	411	985	1084	128	370	996	170	780	1343	846	368
22SV08F110T	100	100	354	411	985	1084	260	440	1400	170	807	1512	973	401
22SV10F110T	100	100	354	411	985	1084	260	440	1400	170	807	1608	973	401

Dimensions in mm. Tolerance ± 10 mm.
Antivibration feet will add 25mm to the set height.

**GHV30 SERIES 3 PUMP BOOSTER SETS DIMENSIONS,
F VERSION**

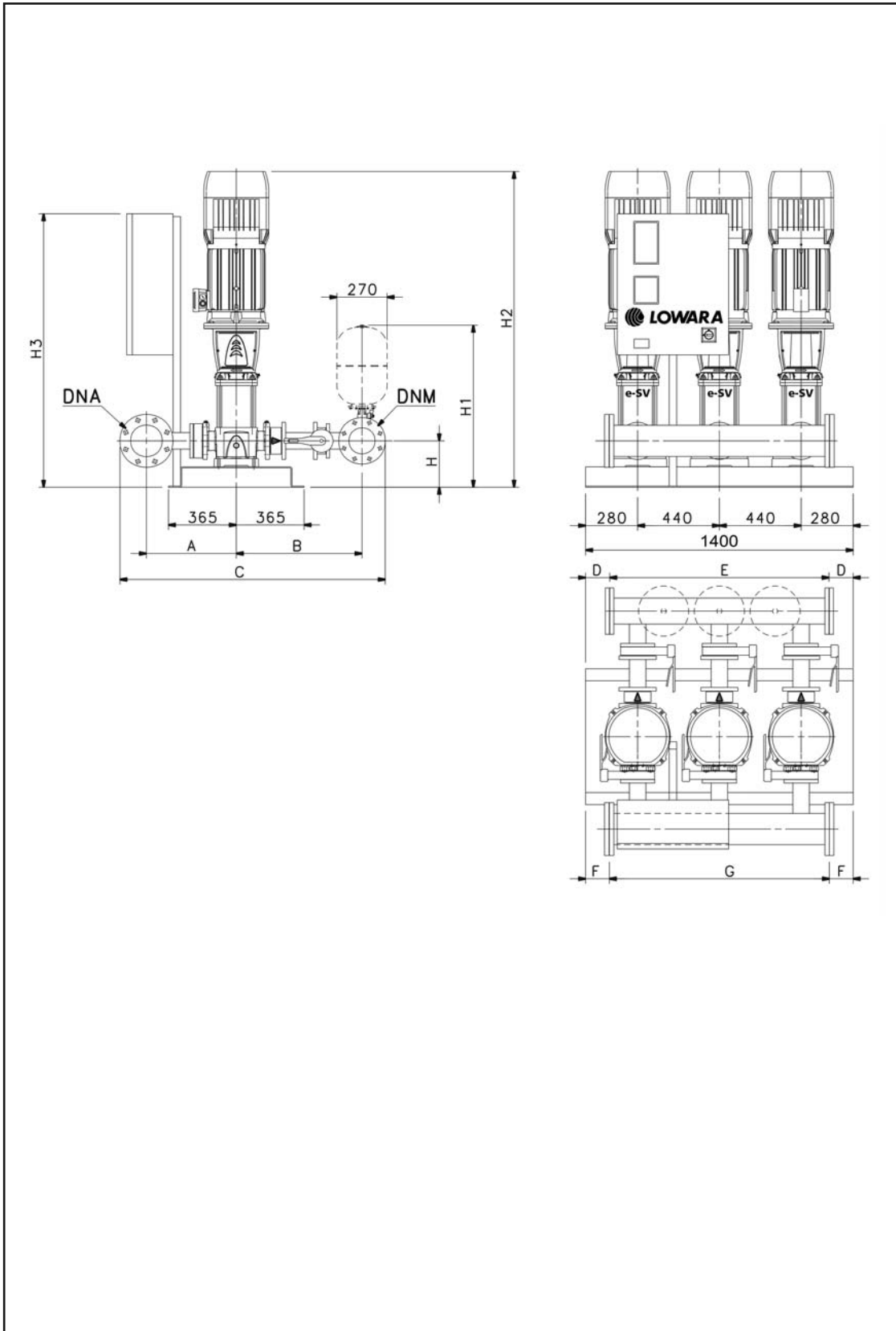

GHV30 SERIES 3 PUMP BOOSTER SETS DIMENSIONS, F VERSION

GHV 30	DNA	DNM	A	B	C	D	E	F	G	H	H1	H2	H3	kg
33SV1/1AG022T	125	100	461	713	1423	90	1220	90	1220	215	822	1032	1097	920
33SV1G030T	125	100	461	713	1423	90	1220	90	1220	215	822	1067	1097	920
33SV2/2AG040T	125	100	461	713	1423	90	1220	90	1220	215	822	1163	1097	920
33SV2/1AG040T	125	100	461	713	1423	90	1220	90	1220	215	822	1163	1097	920
33SV2G055T	125	100	461	713	1423	90	1220	90	1220	215	822	1239	1097	920
33SV3/2AG055T	125	100	461	713	1423	90	1220	90	1220	215	822	1314	1097	920
33SV3/1AG075T	125	100	461	713	1423	90	1220	90	1220	215	822	1306	1097	920
33SV3G075T	125	100	461	713	1423	90	1220	90	1220	215	822	1306	1097	920
33SV4/2AG075T	125	100	461	713	1423	90	1220	90	1220	215	822	1381	1097	920
33SV4/1AG110T	125	100	461	713	1423	90	1220	90	1220	215	822	1477	974	920
33SV4G110T	125	100	461	713	1423	90	1220	90	1220	215	822	1477	974	920
33SV5/2AG110T	125	100	461	713	1423	90	1220	90	1220	215	822	1552	974	920
33SV5/1AG110T	125	100	461	713	1423	90	1220	90	1220	215	822	1552	974	920
33SV5G150T	125	100	461	713	1423	90	1220	90	1220	215	822	1656	974	920
33SV6/2AG150T	125	100	461	713	1423	90	1220	90	1220	215	822	1731	974	920
33SV6/1AG150T	125	100	461	713	1423	90	1220	90	1220	215	822	1731	974	920
33SV6G150T	125	100	461	713	1423	90	1220	90	1220	215	822	1731	974	920
33SV7/2AG150T	125	100	461	713	1423	90	1220	90	1220	215	822	1806	974	920
46SV1/1AG030T	150	125	498	752	1517	90	1220	70	1260	250	870	1107	1097	1010
46SV1G040T	150	125	498	752	1517	90	1220	70	1260	250	870	1128	1097	1010
46SV2/2AG055T	150	125	498	752	1517	90	1220	70	1260	250	870	1279	1097	1010
46SV2G075T	150	125	498	752	1517	90	1220	70	1260	250	870	1271	1097	1010
46SV3/2AG110T	150	125	498	752	1517	90	1220	70	1260	250	870	1442	974	1010
46SV3G110T	150	125	498	752	1517	90	1220	70	1260	250	870	1442	974	1010
46SV4/2AG150T	150	125	498	752	1517	90	1220	70	1260	250	870	1621	974	1010
46SV4G150T	150	125	498	752	1517	90	1220	70	1260	250	870	1621	974	1010
46SV5/2AG185T	150	125	498	752	1517	90	1220	70	1260	250	870	1696	974	1010
46SV5G185T	150	125	498	752	1517	90	1220	70	1260	250	870	1696	974	1010
46SV6/2AG220T	150	125	498	752	1517	90	1220	70	1260	250	870	1771	974	1010
46SV6G220T	150	125	498	752	1517	90	1220	70	1260	250	870	1771	974	1010
66SV1/1AG040T	200	150	529	794	1635	70	1260	70	1260	250	884	1153	1097	1370
66SV1G055T	200	150	529	794	1635	70	1260	70	1260	250	884	1229	1097	1370
66SV2/2AG075T	200	150	529	794	1635	70	1260	70	1260	250	884	1311	1097	1370
66SV2/1AG110T	200	150	529	794	1635	70	1260	70	1260	250	884	1407	1194	1370
66SV2G110T	200	150	529	794	1635	70	1260	70	1260	250	884	1407	1194	1370
66SV3/2AG150T	200	150	529	794	1635	70	1260	70	1260	250	884	1601	1194	1370
66SV3/1AG150T	200	150	529	794	1635	70	1260	70	1260	250	884	1601	1194	1370
66SV3G185T	200	150	529	794	1635	70	1260	70	1260	250	884	1601	1194	1370
66SV4/2AG185T	200	150	529	794	1635	70	1260	70	1260	250	884	1691	1194	1370
66SV4/1AG220T	200	150	529	794	1635	70	1260	70	1260	250	884	1691	1194	1370
66SV4G220T	200	150	529	794	1635	70	1260	70	1260	250	884	1691	1194	1370
92SV1/1AG055T	200	200	529	819	1688	70	1260	70	1260	250	910	1229	1097	1470
92SV1G075T	200	200	529	819	1688	70	1260	70	1260	250	910	1221	1097	1470
92SV2/2AG110T	200	200	529	819	1688	70	1260	70	1260	250	910	1407	1194	1470
92SV2G150T	200	200	529	819	1688	70	1260	70	1260	250	910	1511	1194	1470
92SV3/2AG185T	200	200	529	819	1688	70	1260	70	1260	250	910	1601	1194	1470
92SV3G220T	200	200	529	819	1688	70	1260	70	1260	250	910	1601	1194	1470

Dimensions in mm. Tolerance ± 10 mm.
 Antivibration feet will add 25mm to the set height.

GHV40 SERIES 4 PUMP BOOSTER SETS DIMENSIONS, F VERSION

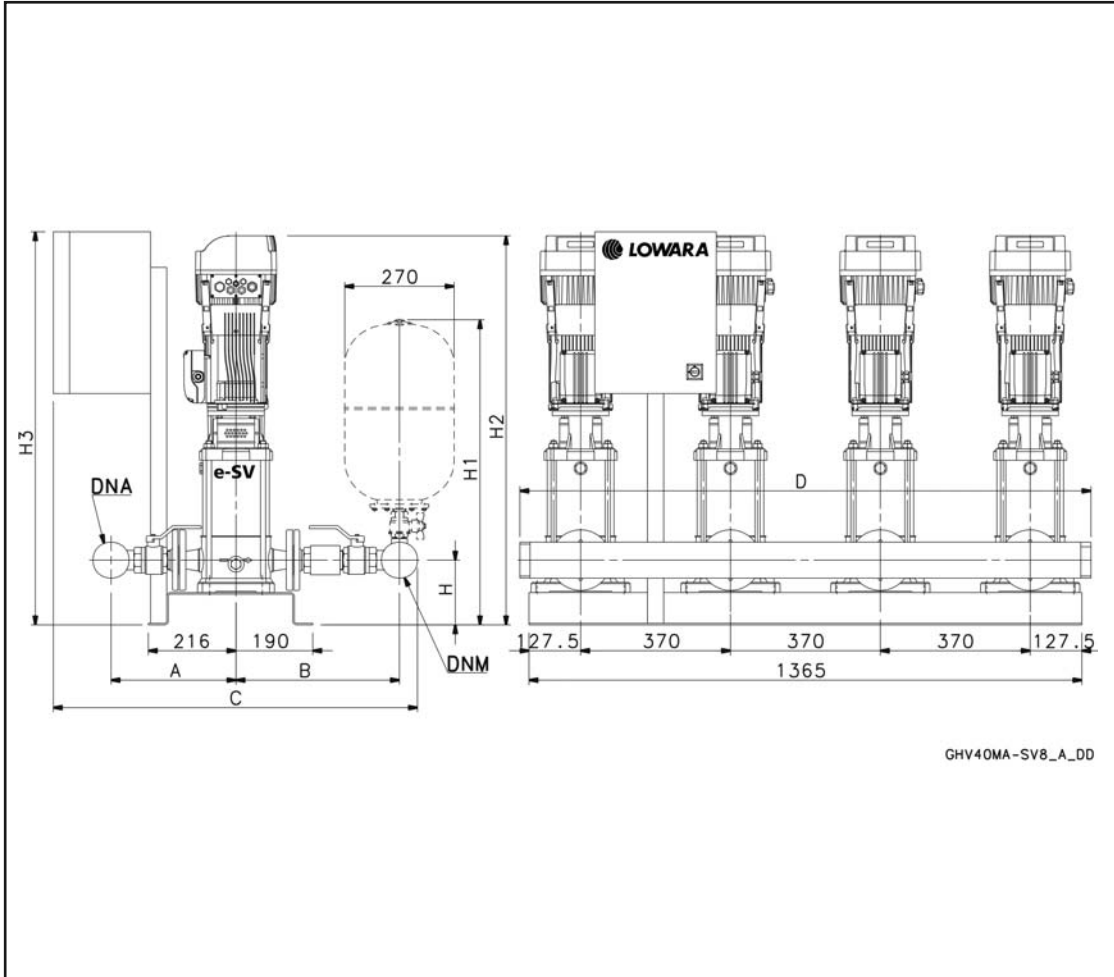

GHV40	DNA	DNM	A	B	C	D	H	H1	H2	H3	Kg
5SV04F005T/UK	R2 1/2"	R2"	265	327	652	1410	109	765	753	700	270
5SV05F007T/UK	R2 1/2"	R2"	265	327	652	1410	109	765	820	700	290
5SV06F011T/UK	R2 1/2"	R2"	265	327	652	1410	109	765	845	700	290
5SV07F011T/UK	R2 1/2"	R2"	265	327	652	1410	109	765	870	700	290
5SV08011T/UK	R2 1/2"	R2"	265	327	652	1410	109	765	895	700	290
5SV09F015T/UK	R2 1/2"	R2"	265	327	652	1410	109	765	930	700	320
5SV11F015T/UK	R2 1/2"	R2"	265	327	652	1410	109	765	980	700	320
5SV13F022T/UK	R2 1/2"	R2"	265	327	652	1410	109	765	1065	700	360
5SV14F022T/UK	R2 1/2"	R2"	265	327	652	1410	109	765	1090	700	360
5SV16F022T/UK	R2 1/2"	R2"	265	327	652	1410	109	765	1140	700	360

Dimensions in mm. Tolerance ± 10 mm.
Antivibration feet will add 25mm to the set height.

GHV40 SERIES 4 PUMP BOOSTER SETS DIMENSIONS, F VERSION

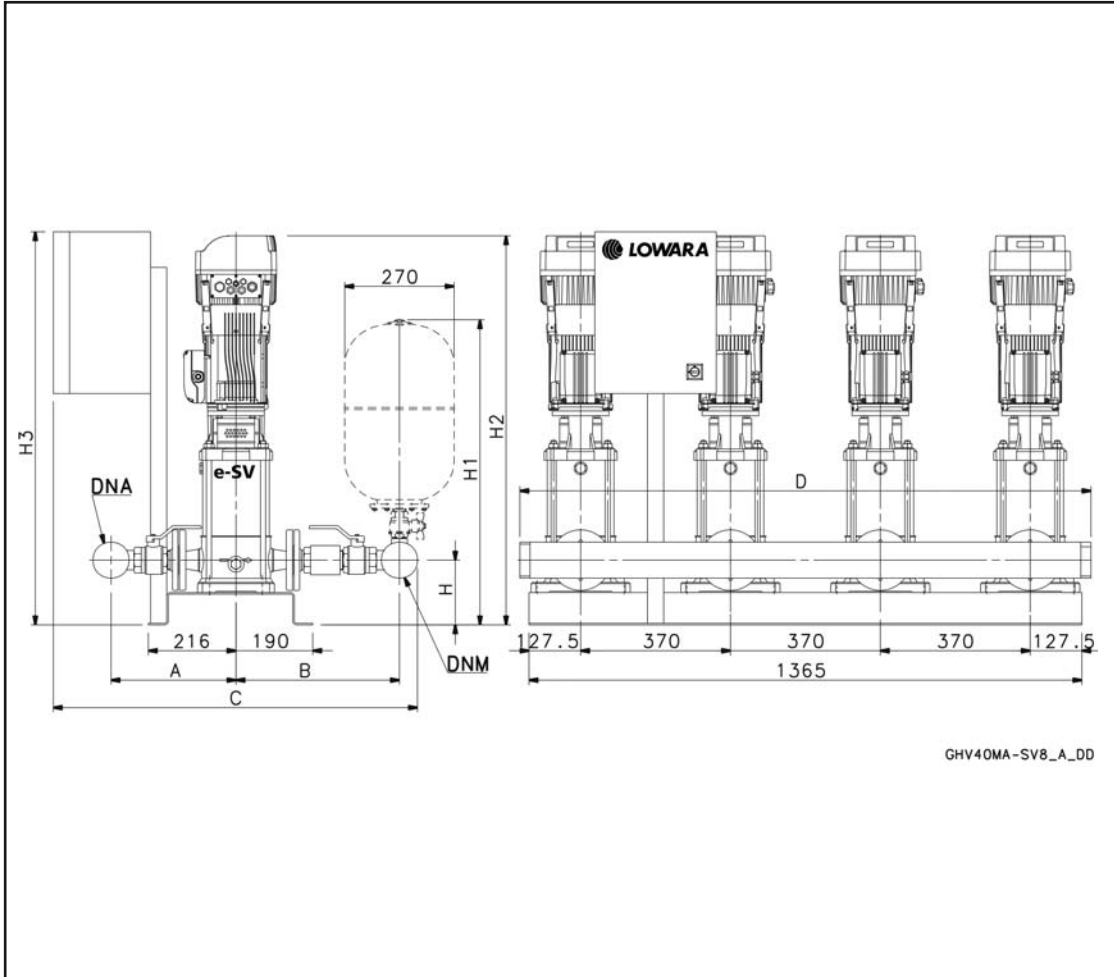

GHV40	DNA	DNM	A	B	C	D	H	H1	H2	H3	Kg
10SV04F015T/UK	R3"	R3"	304	369	761	1410	160	755	979	846	430
10SV05F022T/UK	R3"	R3"	304	369	761	1410	160	755	1011	846	440
10SV06F022T/UK	R3"	R3"	304	369	761	1410	160	755	1043	846	450
10SV07F030T/UK	R3"	R3"	304	369	761	1410	160	755	1085	846	460
10SV09F040T/UK	R3"	R3"	304	369	761	1410	160	755	1170	846	470
10SV10F040T/UK	R3"	R3"	304	369	761	1410	160	755	1202	846	480
10SV13F055T/UK	R3"	R3"	304	369	761	1410	160	755	1421	846	490

Dimensions in mm. Tolerance ± 10 mm.
Antivibration feet will add 25mm to the set height.

GHV40 SERIES 4 PUMP BOOSTER SETS DIMENSIONS, F VERSION

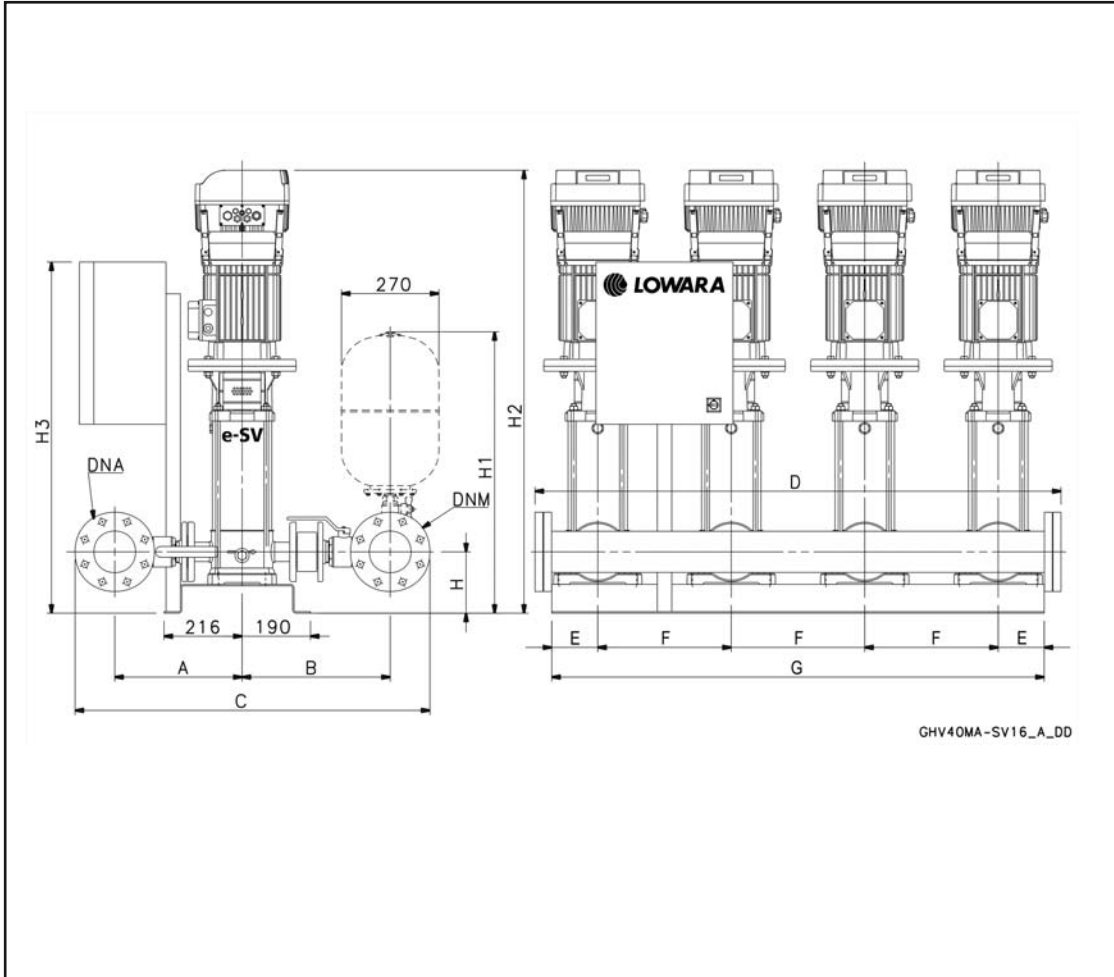

GHV40	DNA	DNM	A	B	C	D	E	F	G	H	H1	H2	H3	Kg
15SV03F030T/UK	100	100	354	411	985	1454	128	370	1365	170	777	1015	846	430
15SV04F040T/UK	100	100	354	411	985	1454	128	370	1365	170	777	1084	846	445
15SV05F040T/UK	100	100	354	411	985	1454	128	370	1365	170	777	1132	846	460
15SV06F055T/UK	100	100	354	411	985	1454	128	370	1365	170	777	1303	846	475
15SV07F055T/UK	100	100	354	411	985	1454	128	370	1365	170	777	1351	846	490
15SV08F075T/UK	100	100	354	411	985	1454	128	370	1365	170	777	1391	1193	505
15SV09F075T/UK	100	100	354	411	985	1454	128	370	1365	170	777	1439	1193	520
15SV10F110T/UK	100	100	354	411	985	1454	280	440	1880	200	807	1608	1193	535

Dimensions in mm. Tolerance ± 10 mm.

Antivibration feet will add 25mm to the set height.

GHV40 SERIES 4 PUMP BOOSTER SETS DIMENSIONS, F VERSION

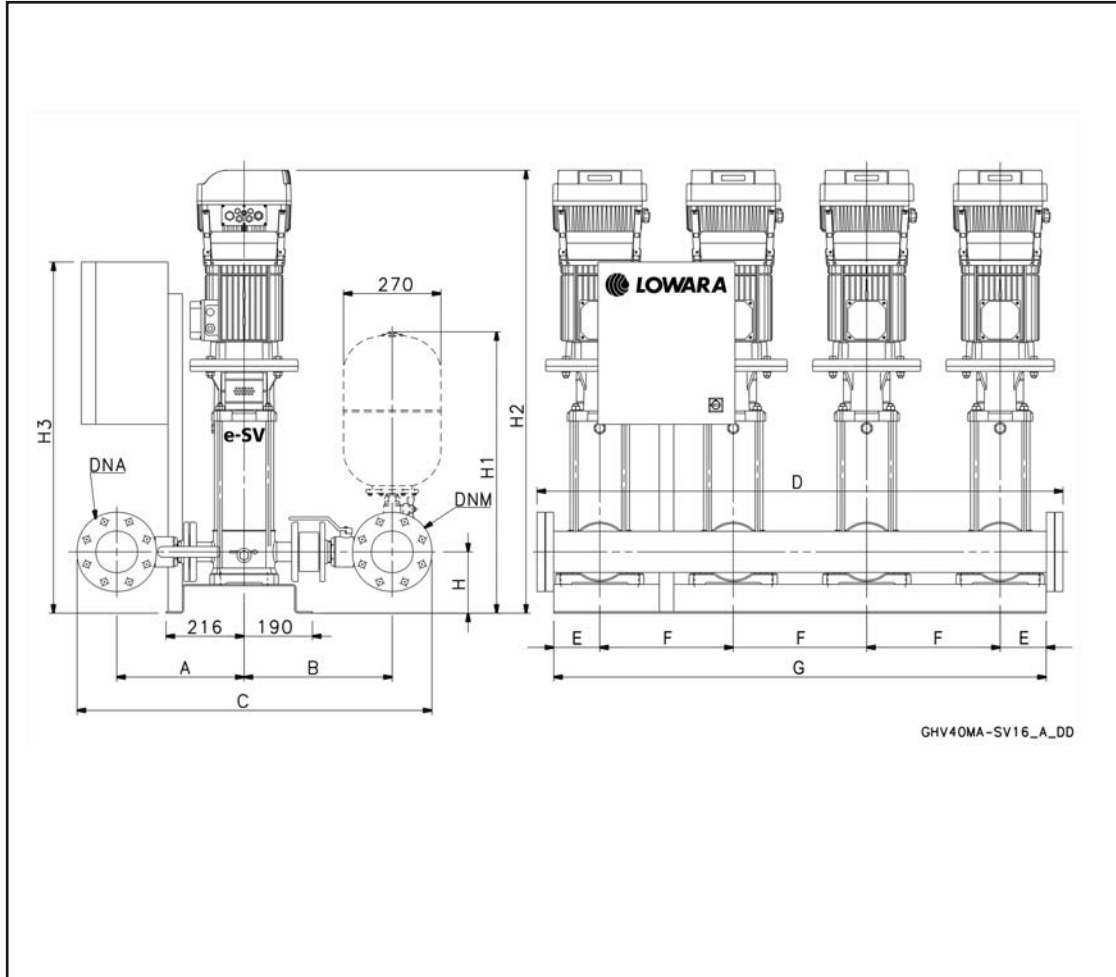

GHV40	DNA	DNM	A	B	C	D	E	F	G	H	H1	H2	H3	Kg
22SV02F022T/UK	125	100	367	411	1013	1454	128	370	1365	170	777	912	746	415
22SV03F030T/UK	125	100	367	411	1013	1454	128	370	1365	170	777	957	746	430
22SV04F040T/UK	125	100	367	411	1013	1454	128	370	1365	170	777	1015	746	445
22SV05F055T/UK	125	100	367	411	1013	1454	128	370	1365	170	777	1084	689	460
22SV06F075T/UK	125	100	367	411	1013	1454	128	370	1365	170	777	1255	1295	475
22SV07F075T/UK	125	100	367	411	1013	1454	128	370	1365	170	777	1343	1343	490
22SV08F110T/UK	125	100	367	411	1013	1664	280	440	1880	200	807	1512	1512	535
22SV10F110T/UK	125	100	367	411	1013	1664	280	440	1880	200	807	1608	1608	535

Dimensions in mm. Tolerance ± 10 mm.
Antivibration feet will add 25mm to the set height.

**GHV40 SERIES 4 PUMP BOOSTER SETS DIMENSIONS,
F VERSION**

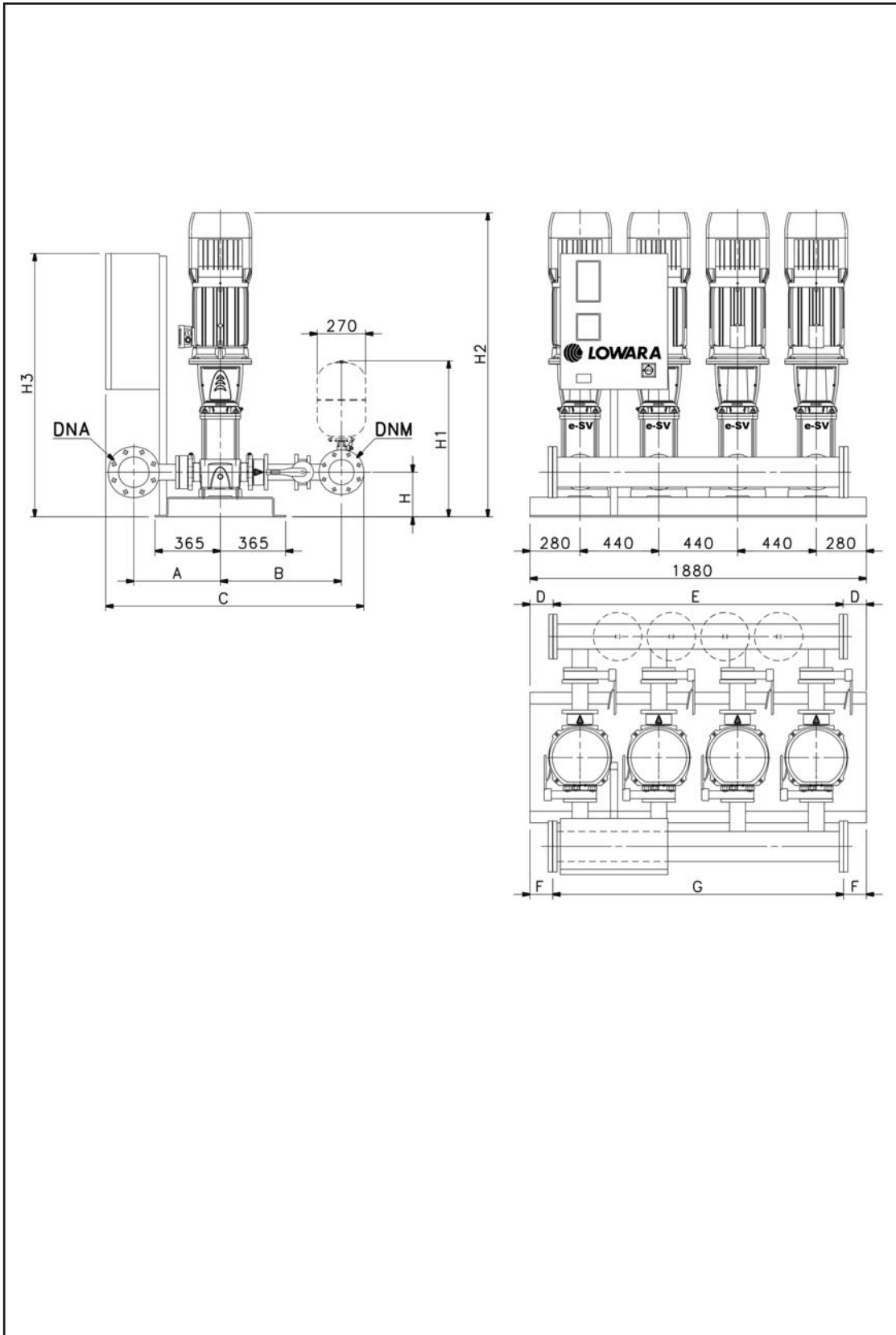

GHV40 SERIES 4 PUMP BOOSTER SETS DIMENSIONS, F VERSION

GHV 40	DNA	DNM	A	B	C	D	E	F	G	H	H1	H2	H3	kg
33SV1/1AG022T	125	125	461	726	1451	110	1660	110	1660	215	835	1032	1097	950
33SV1G030T	125	125	461	726	1451	110	1660	110	1660	215	835	1067	1097	950
33SV2/2AG040T	125	125	461	726	1451	110	1660	110	1660	215	835	1163	1097	950
33SV2/1AG040T	125	125	461	726	1451	110	1660	110	1660	215	835	1163	1097	950
33SV2G055T	125	125	461	726	1451	110	1660	110	1660	215	835	1239	1097	1000
33SV3/2AG055T	125	125	461	726	1451	110	1660	110	1660	215	835	1314	1097	1050
33SV3/1AG075T	125	125	461	726	1451	110	1660	110	1660	215	835	1306	974	1050
33SV3G075T	125	125	461	726	1437	110	1660	110	1660	215	835	1306	974	1050
33SV4/2AG075T	125	125	461	726	1437	110	1660	110	1660	215	835	1381	974	1050
33SV4/1AG110T	125	125	461	726	1437	110	1660	110	1660	215	835	1477	974	1100
33SV4G110T	125	125	461	726	1437	110	1660	110	1660	215	835	1477	974	1100
33SV5/2AG110T	125	125	461	726	1437	110	1660	110	1660	215	835	1522	974	1100
33SV5/1AG110T	125	125	461	726	1437	110	1660	110	1660	215	835	1522	974	1100
33SV5G150T	125	125	461	726	1437	110	1660	110	1660	215	835	1656	974	1150
33SV6/2AG150T	125	125	461	726	1437	110	1660	110	1660	215	835	1731	974	1150
33SV6/1AG150T	125	125	461	726	1437	110	1660	110	1660	215	835	1731	974	1150
33SV6G150T	125	125	461	726	1437	110	1660	110	1660	215	835	1731	974	1150
33SV7/2AG150T	125	125	461	726	1437	110	1660	110	1660	215	835	1806	974	1150
46SV1/1AG030T	150	150	498	766	1548	90	1700	90	1700	250	884	1107	1097	1050
46SV1G040T	150	150	498	766	1548	90	1700	90	1700	250	884	1128	1097	1100
46SV2/2AG055T	150	150	498	766	1548	90	1700	90	1700	250	884	1279	1097	1130
46SV2G075T	150	150	498	766	1548	90	1700	90	1700	250	884	1271	1097	1080
46SV3/2AG110T	150	150	498	766	1548	90	1700	90	1700	250	884	1442	974	1130
46SV3G110T	150	150	498	766	1548	90	1700	90	1700	250	884	1442	974	1130
46SV4/2AG150T	150	150	498	766	1548	90	1700	90	1700	250	884	1621	974	1200
46SV4G150T	150	150	498	766	1548	90	1700	90	1700	250	884	1621	974	1200
46SV5/2AG185T	150	150	498	766	1548	90	1700	90	1700	250	884	1696	1121	1200
46SV5G185T	150	150	498	766	1548	90	1700	90	1700	250	884	1696	1121	1200
46SV6/2AG220T	150	150	498	766	1548	90	1700	90	1700	250	884	1771	1121	1200
46SV6G220T	150	150	498	766	1548	90	1700	90	1700	250	884	1771	1121	1200
66SV1/1AG040T	200	200	529	819	1688	90	1700	90	1700	250	910	1153	1097	1400
66SV1G055T	200	200	529	819	1688	90	1700	90	1700	250	910	1229	1097	1400
66SV2/2AG075T	200	200	529	819	1688	90	1700	90	1700	250	910	1311	1097	1400
66SV2/1AG110T	200	200	529	819	1688	90	1700	90	1700	250	910	1407	1194	1410
66SV2G110T	200	200	529	819	1688	90	1700	90	1700	250	910	1407	1194	1410
66SV3/2AG150T	200	200	529	819	1688	90	1700	90	1700	250	910	1601	1194	1500
66SV3/1AG150T	200	200	529	819	1688	90	1700	90	1700	250	910	1601	1194	1500
66SV3G185T	200	200	529	819	1688	90	1700	90	1700	250	910	1601	1121	1550
66SV4/2AG185T	200	200	529	819	1688	90	1700	90	1700	250	910	1691	1121	1550
66SV4/1AG220T	200	200	529	819	1688	90	1700	90	1700	250	910	1691	1121	1550
66SV4G220T	200	200	529	819	1688	90	1700	90	1700	250	910	1691	1121	1550
92SV1/1AG055T	250	200	556	819	1748	90	1700	60	1760	250	910	1229	1097	1470
92SV1G075T	250	200	556	819	1748	90	1700	60	1760	250	910	1221	1194	1470
92SV2/2AG110T	250	200	556	819	1748	90	1700	60	1760	250	910	1407	1194	1470
92SV2G150T	250	200	556	819	1748	90	1700	60	1760	250	910	1511	1194	1550
92SV3/2AG185T	250	200	556	819	1748	90	1700	60	1760	250	910	1601	1121	1550
92SV3G220T	250	200	556	819	1748	90	1700	60	1760	250	910	1601	1121	1550

Dimensions in mm. Tolerance ± 10 mm.

Antivibration feet will add 25mm to the set height.

1SV SERIES, GHV CURVES OPERATING CHARACTERISTICS AT 50 Hz, 2 POLES

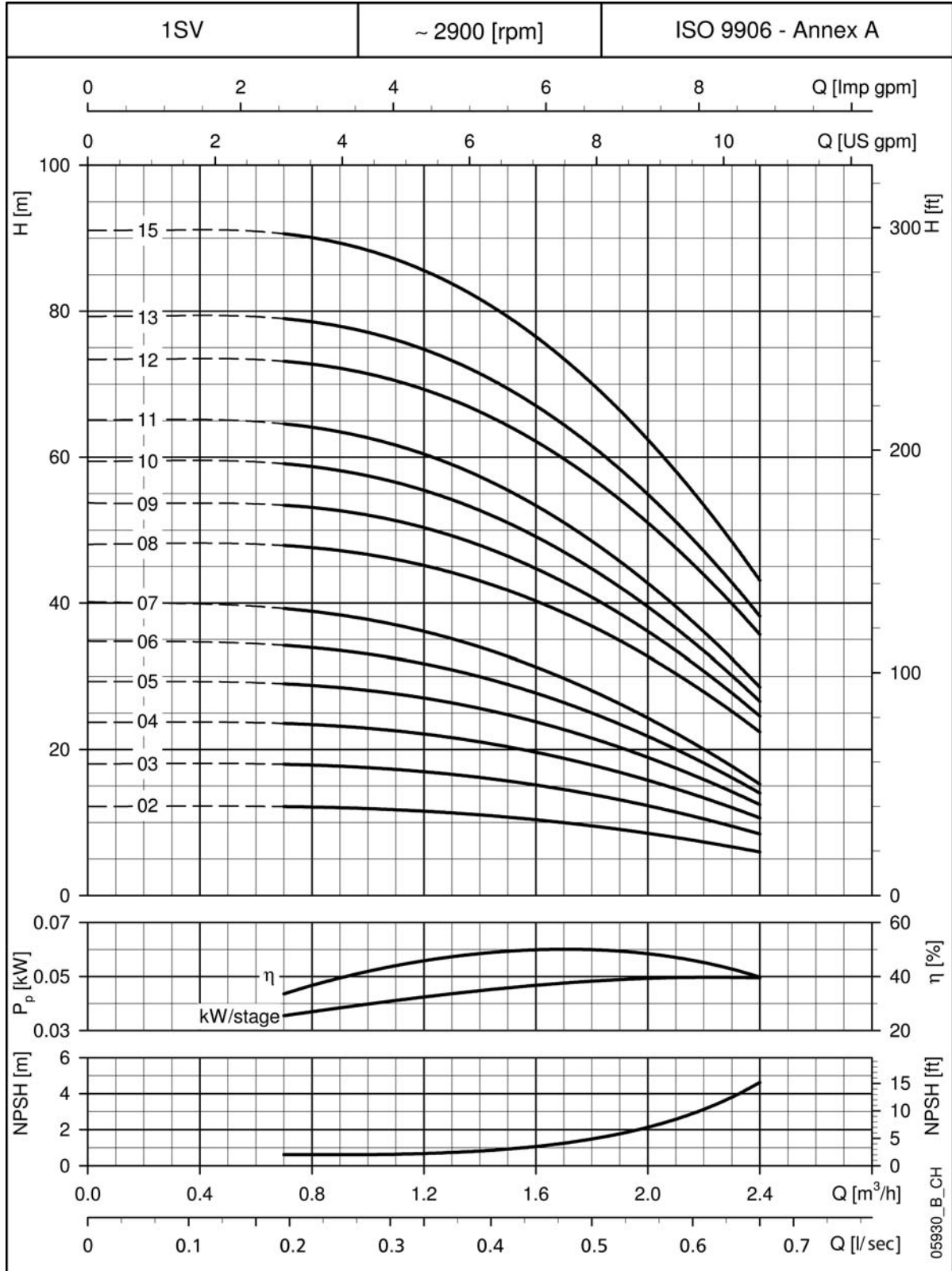

These performances are valid for liquids with density $\rho = 1.0 \text{ kg/dm}^3$ and kinematic viscosity $\nu = 1 \text{ mm}^2/\text{s}$.
 Booster Sets which are above 16bar pressure rating are available on request.
 Performance curves based on a single pump running, set losses are not included.

1SV SERIES, GHV CURVES OPERATING CHARACTERISTICS AT 50 Hz, 2 POLES

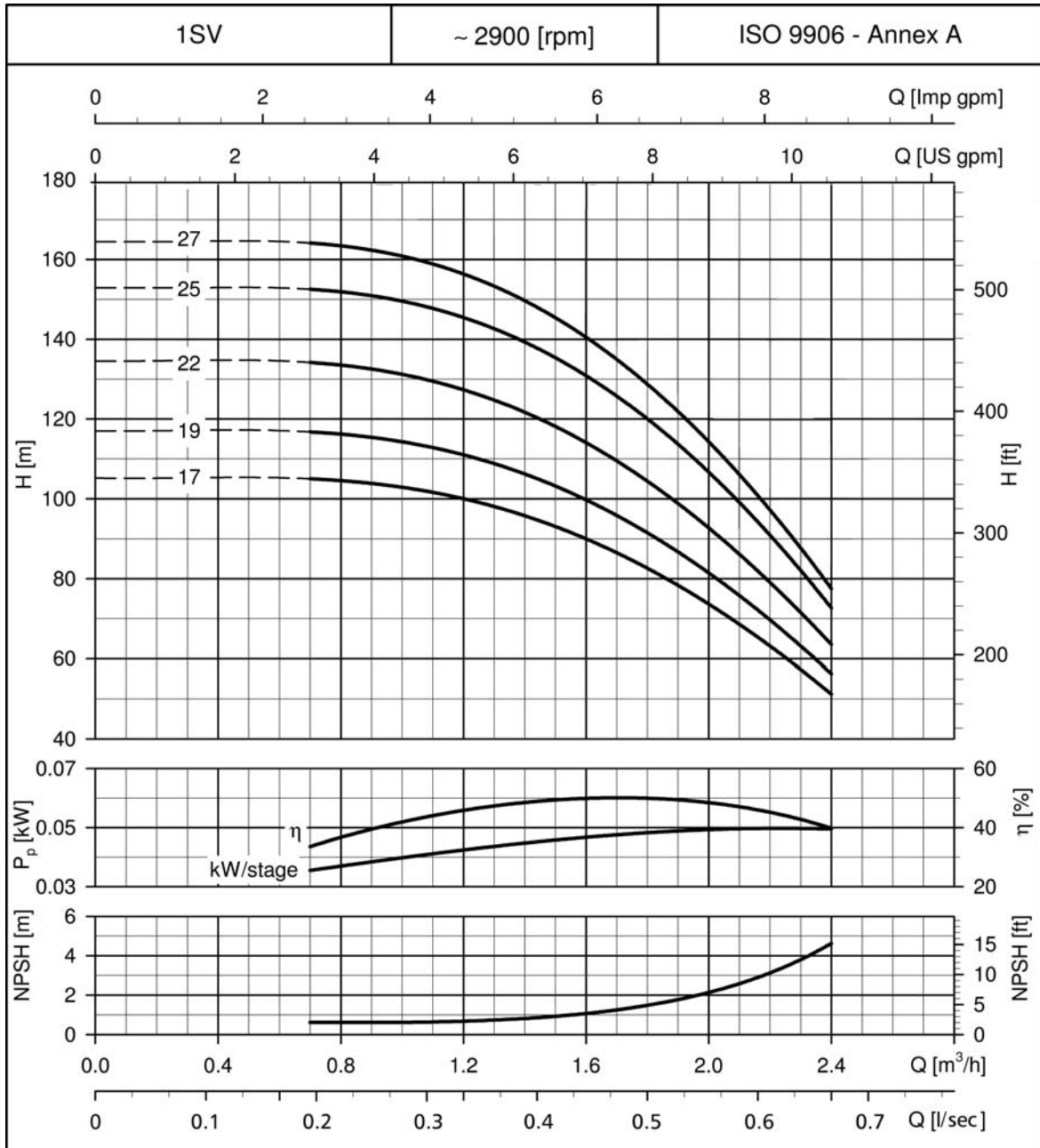

These performances are valid for liquids with density $\rho = 1.0 \text{ kg/dm}^3$ and kinematic viscosity $\nu = 1 \text{ mm}^2/\text{s}$.
 Booster Sets which are above 16bar pressure rating are available on request.
 Performance curves based on a single pump running, set losses are not included.

3SV SERIES, GHV CURVES OPERATING CHARACTERISTICS AT 50 Hz, 2 POLES

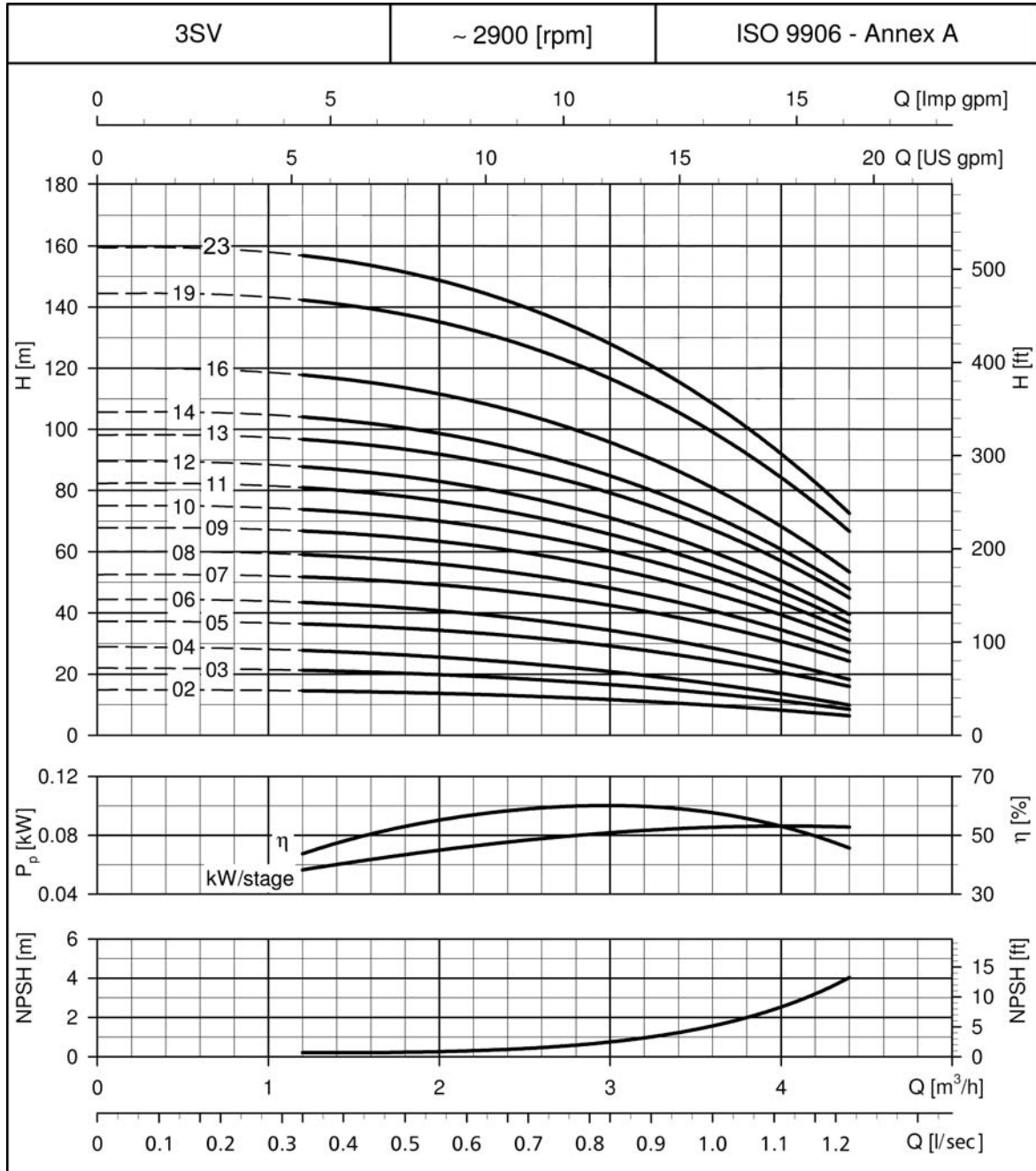

These performances are valid for liquids with density $\rho = 1.0 \text{ kg/dm}^3$ and kinematic viscosity $\nu = 1 \text{ mm}^2/\text{s}$.
 Booster Sets which are above 16bar pressure rating are available on request.
 Performance curves based on a single pump running, set losses are not included.

5SV SERIES, GHV CURVES OPERATING CHARACTERISTICS AT 50 Hz, 2 POLES

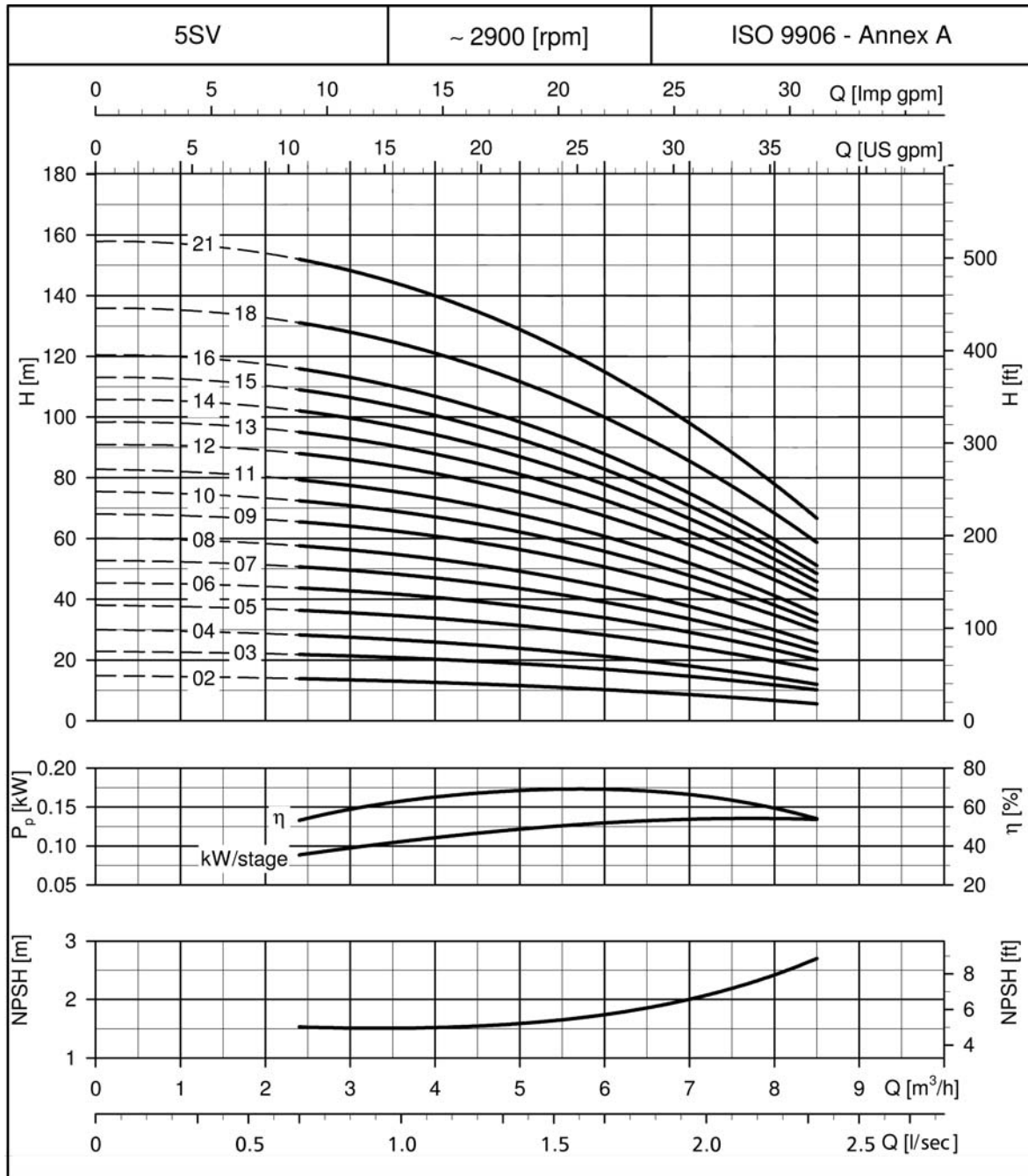

These performances are valid for liquids with density $\rho = 1.0 \text{ kg/dm}^3$ and kinematic viscosity $\nu = 1 \text{ mm}^2/\text{s}$.
 Booster Sets which are above 16bar pressure rating are available on request.
 Performance curves based on a single pump running, set losses are not included.

10SV SERIES, GHV CURVES OPERATING CHARACTERISTICS AT 50 Hz, 2 POLES

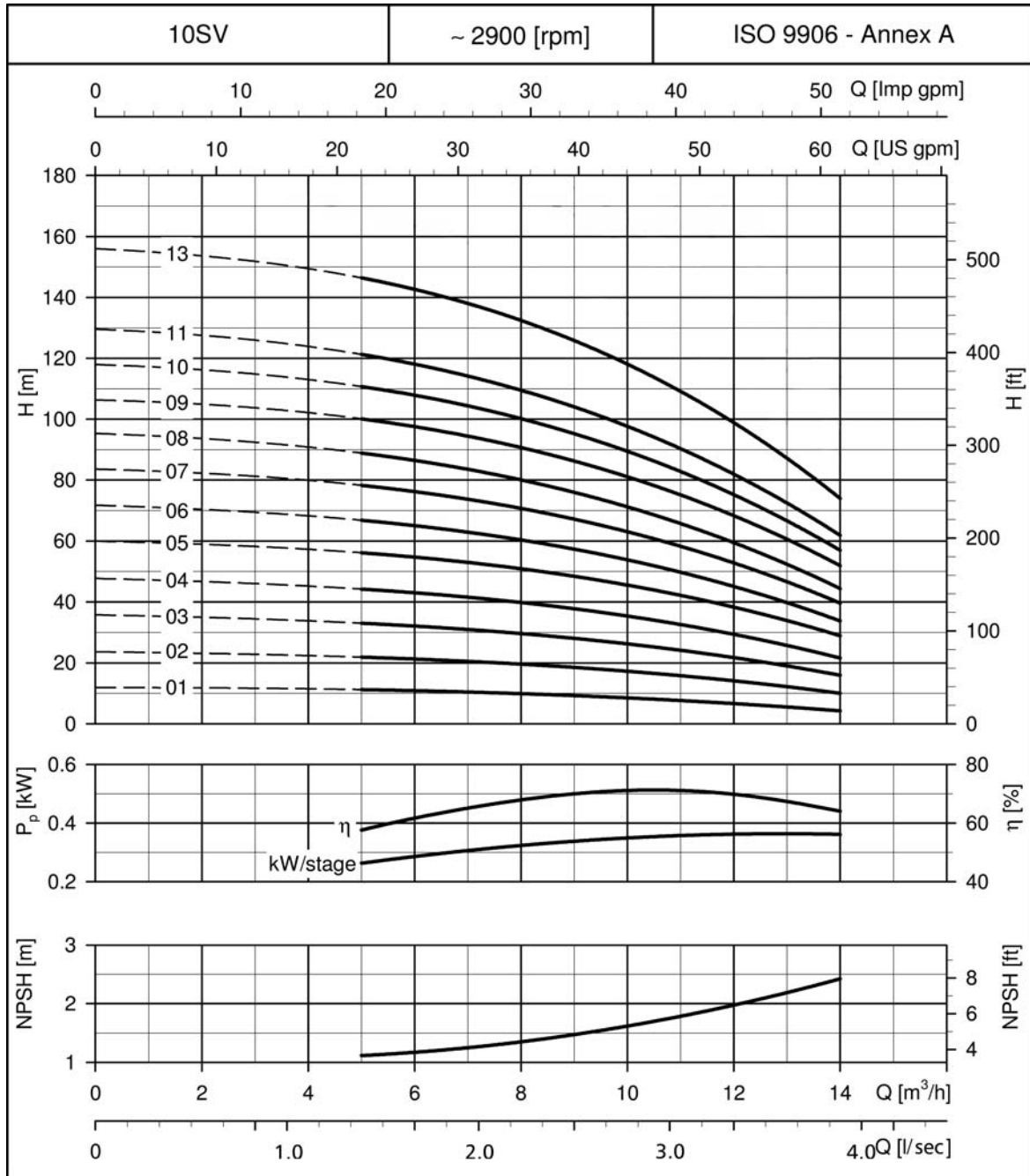

These performances are valid for liquids with density $\rho = 1.0 \text{ kg/dm}^3$ and kinematic viscosity $\nu = 1 \text{ mm}^2/\text{s}$.
 Booster Sets which are above 16bar pressure rating are available on request.
 Performance curves based on a single pump running, set losses are not included.

15SV SERIES, GHV CURVES OPERATING CHARACTERISTICS AT 50 Hz, 2 POLES

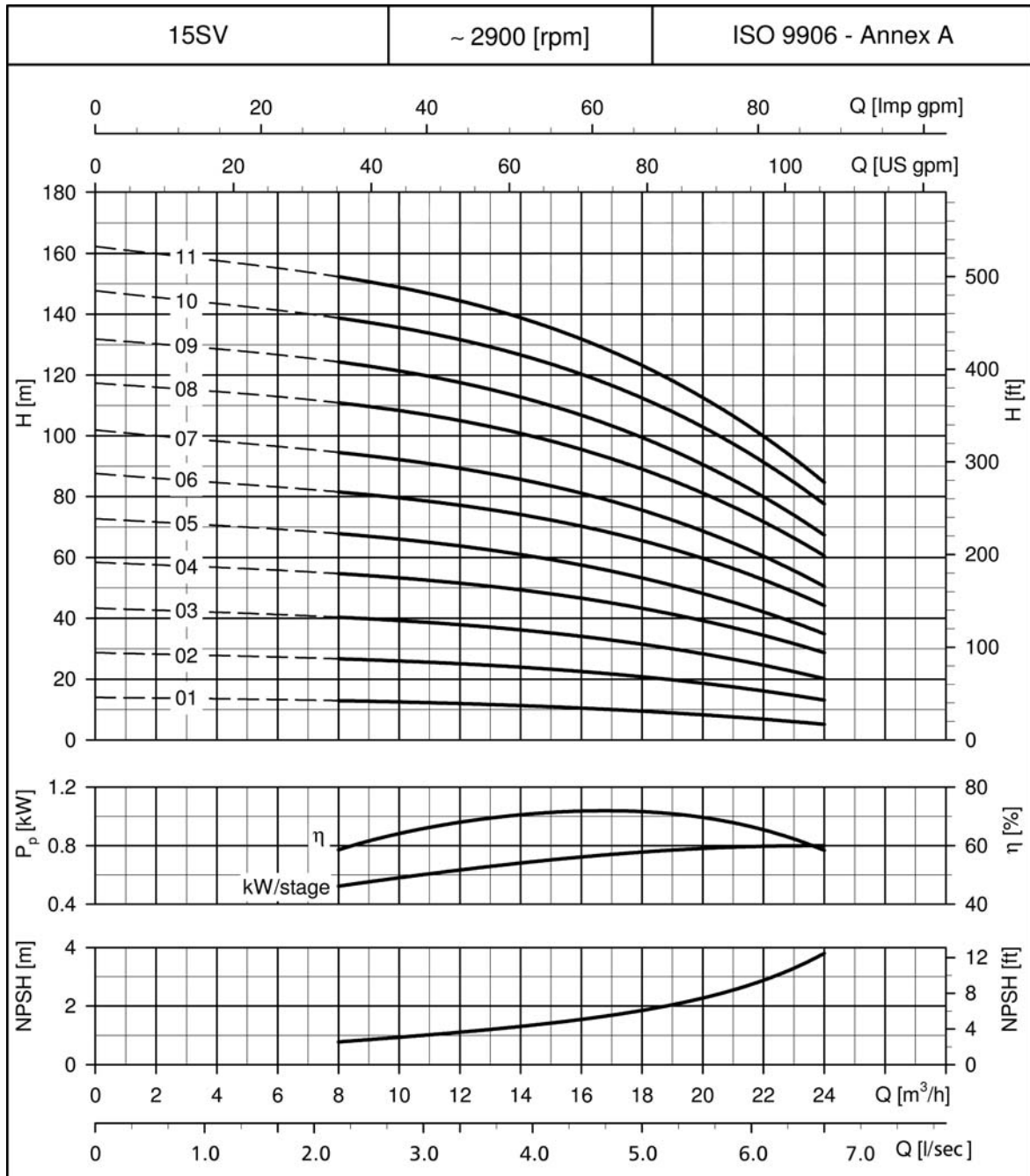

These performances are valid for liquids with density $\rho = 1.0 \text{ kg/dm}^3$ and kinematic viscosity $\nu = 1 \text{ mm}^2/\text{s}$.
 Booster Sets which are above 16bar pressure rating are available on request.
 Performance curves based on a single pump running, set losses are not included.

22SV SERIES, GHV CURVES OPERATING CHARACTERISTICS AT 50 Hz, 2 POLES

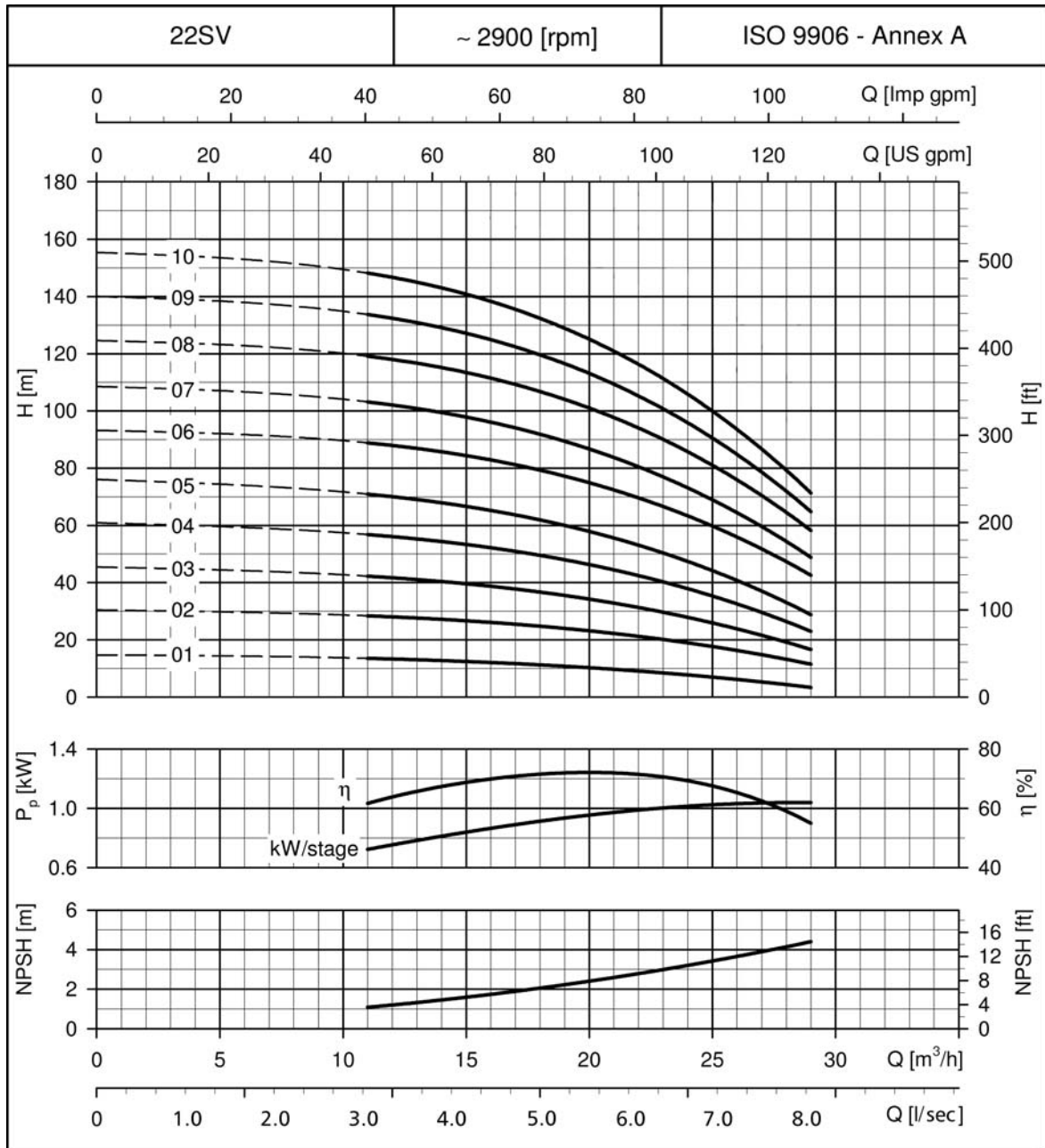

These performances are valid for liquids with density $\rho = 1.0 \text{ kg/dm}^3$ and kinematic viscosity $\nu = 1 \text{ mm}^2/\text{s}$.
 Booster Sets which are above 16bar pressure rating are available on request.
 Performance curves based on a single pump running, set losses are not included.

33SV SERIES, GHV CURVES OPERATING CHARACTERISTICS AT 50 Hz, 2 POLES

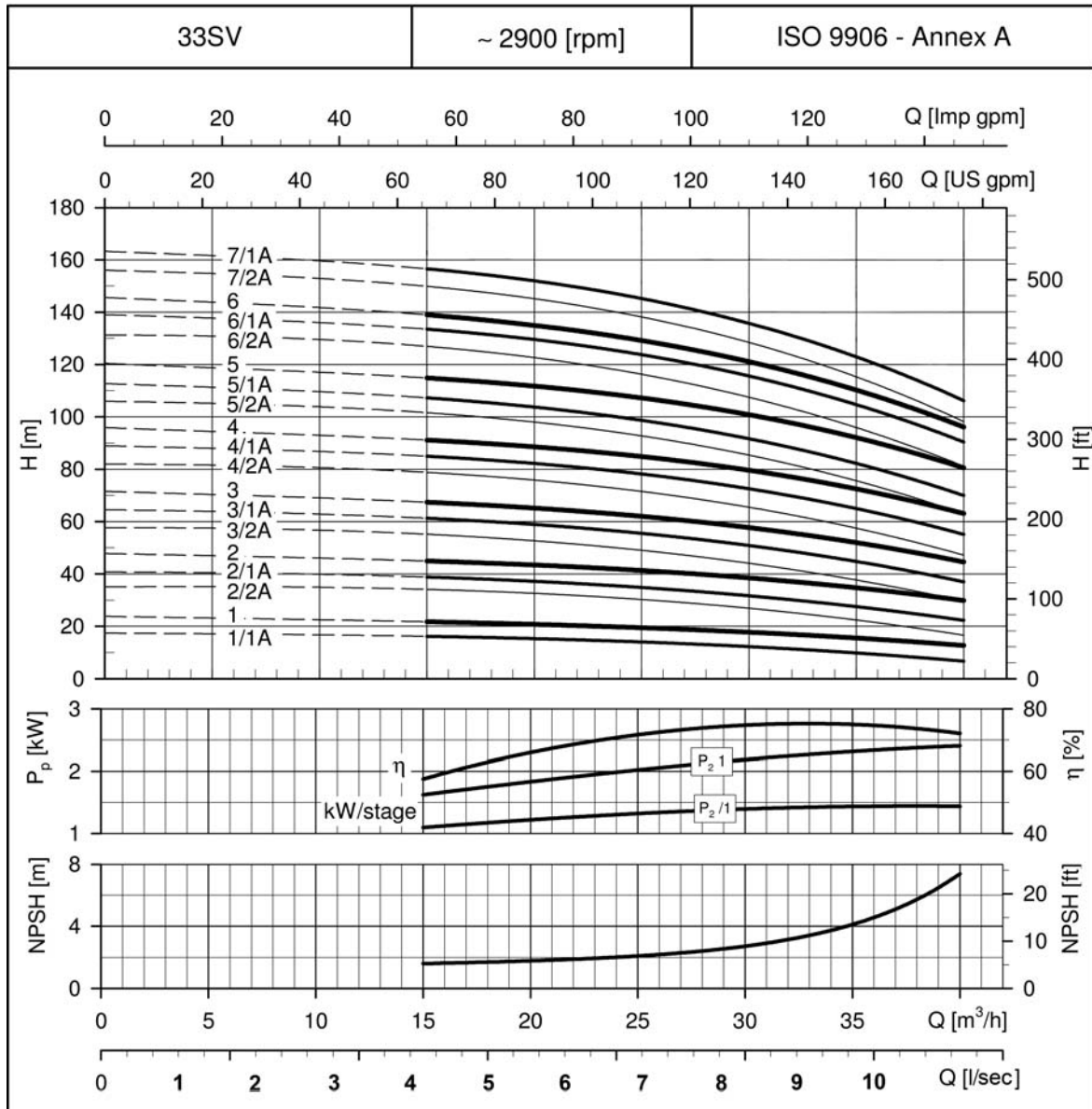

These performances are valid for liquids with density $\rho = 1.0 \text{ kg/dm}^3$ and kinematic viscosity $\nu = 1 \text{ mm}^2/\text{s}$.
 Booster Sets which are above 16bar pressure rating are available on request.
 Performance curves based on a single pump running, set losses are not included.

46SV SERIES, GHV CURVES OPERATING CHARACTERISTICS AT 50 Hz, 2 POLES

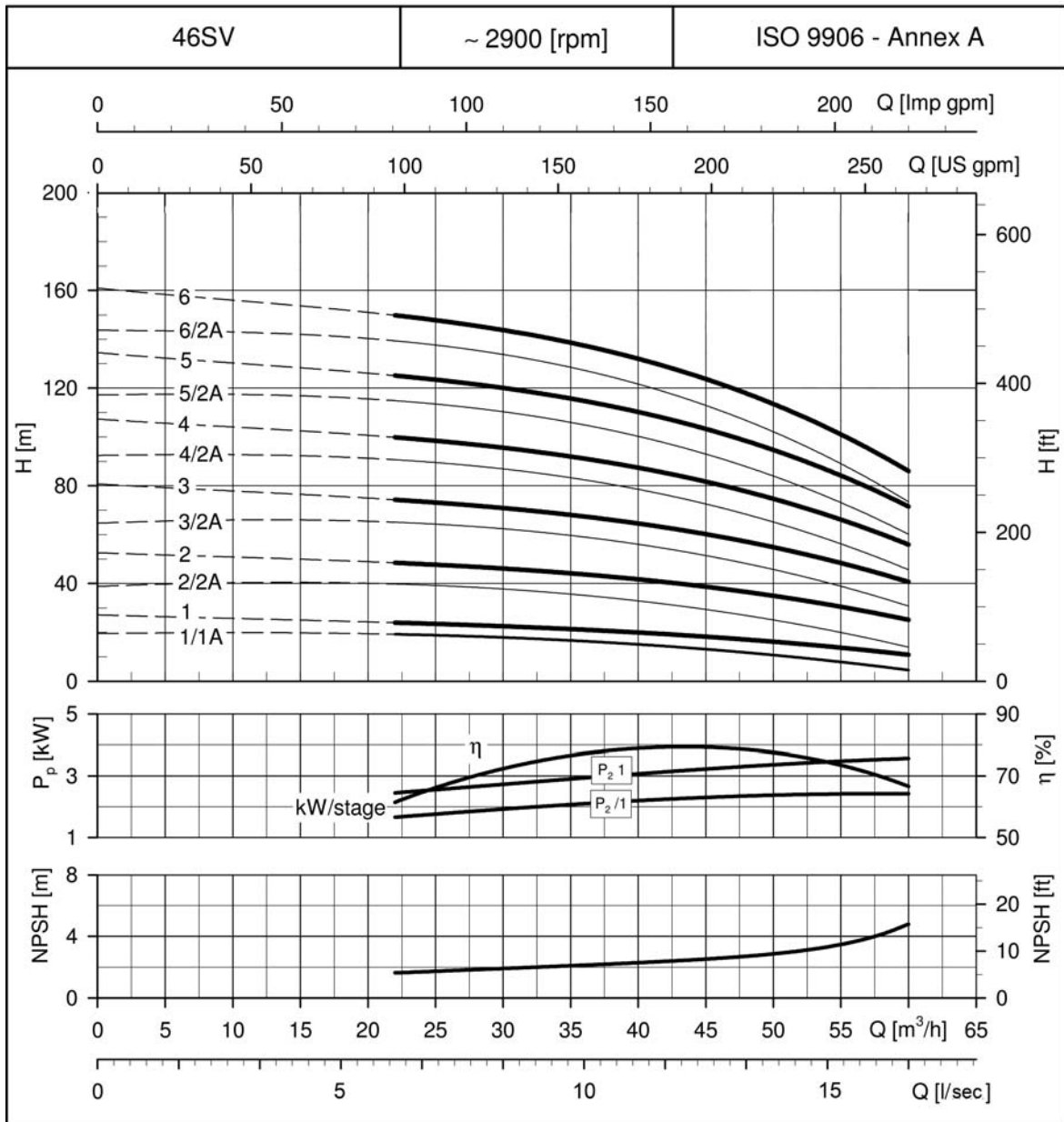

These performances are valid for liquids with density $\rho = 1.0 \text{ kg/dm}^3$ and kinematic viscosity $\nu = 1 \text{ mm}^2/\text{s}$.
 Booster Sets which are above 16bar pressure rating are available on request.
 Performance curves based on a single pump running, set losses are not included.

66SV SERIES, GHV CURVES OPERATING CHARACTERISTICS AT 50 Hz, 2 POLES

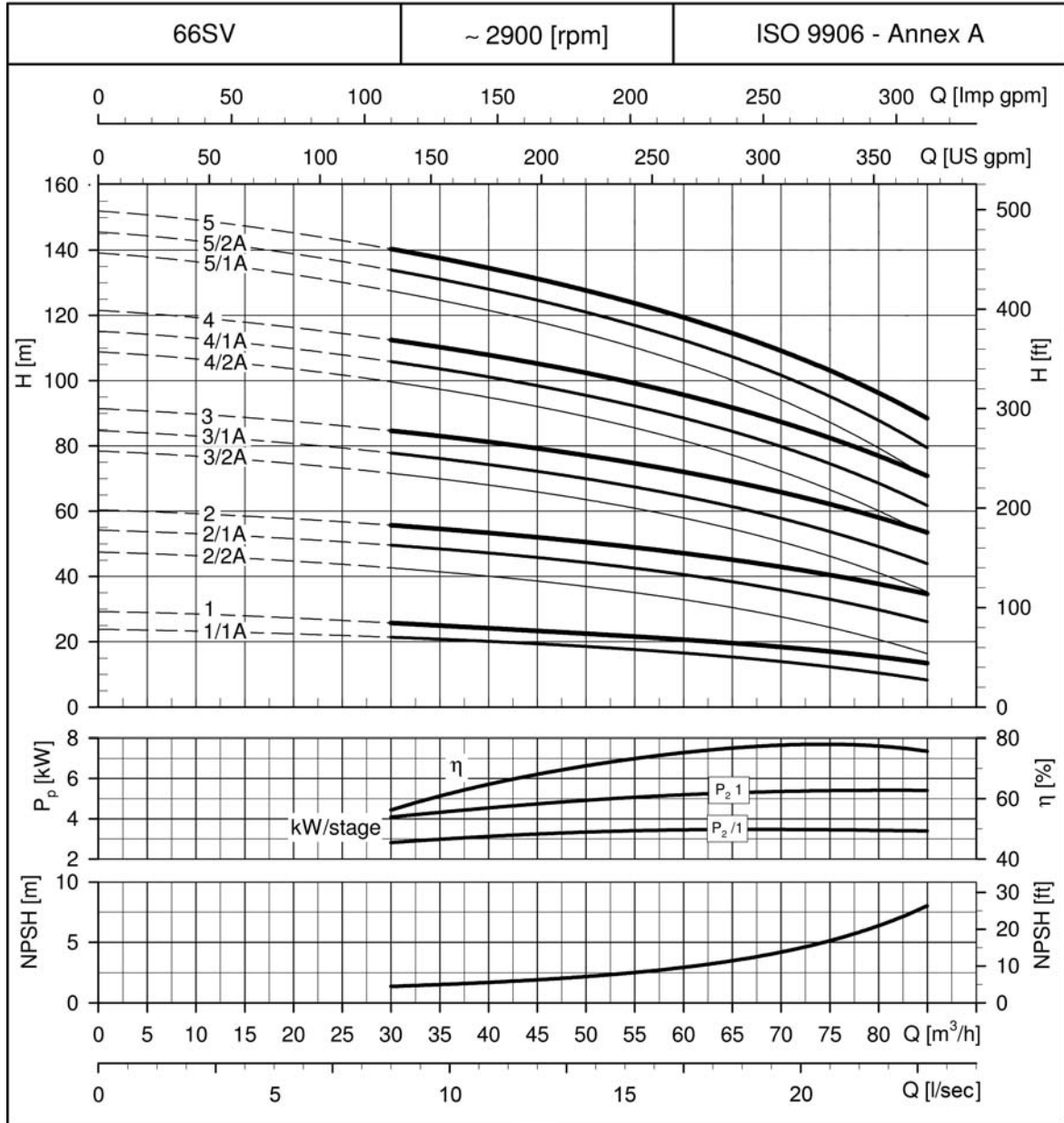

These performances are valid for liquids with density $\rho = 1.0 \text{ kg/dm}^3$ and kinematic viscosity $\nu = 1 \text{ mm}^2/\text{s}$.
 Booster Sets which are above 16bar pressure rating are available on request.
 Performance curves based on a single pump running, set losses are not included.

92SV SERIES, GHV CURVES OPERATING CHARACTERISTICS AT 50 Hz, 2 POLES

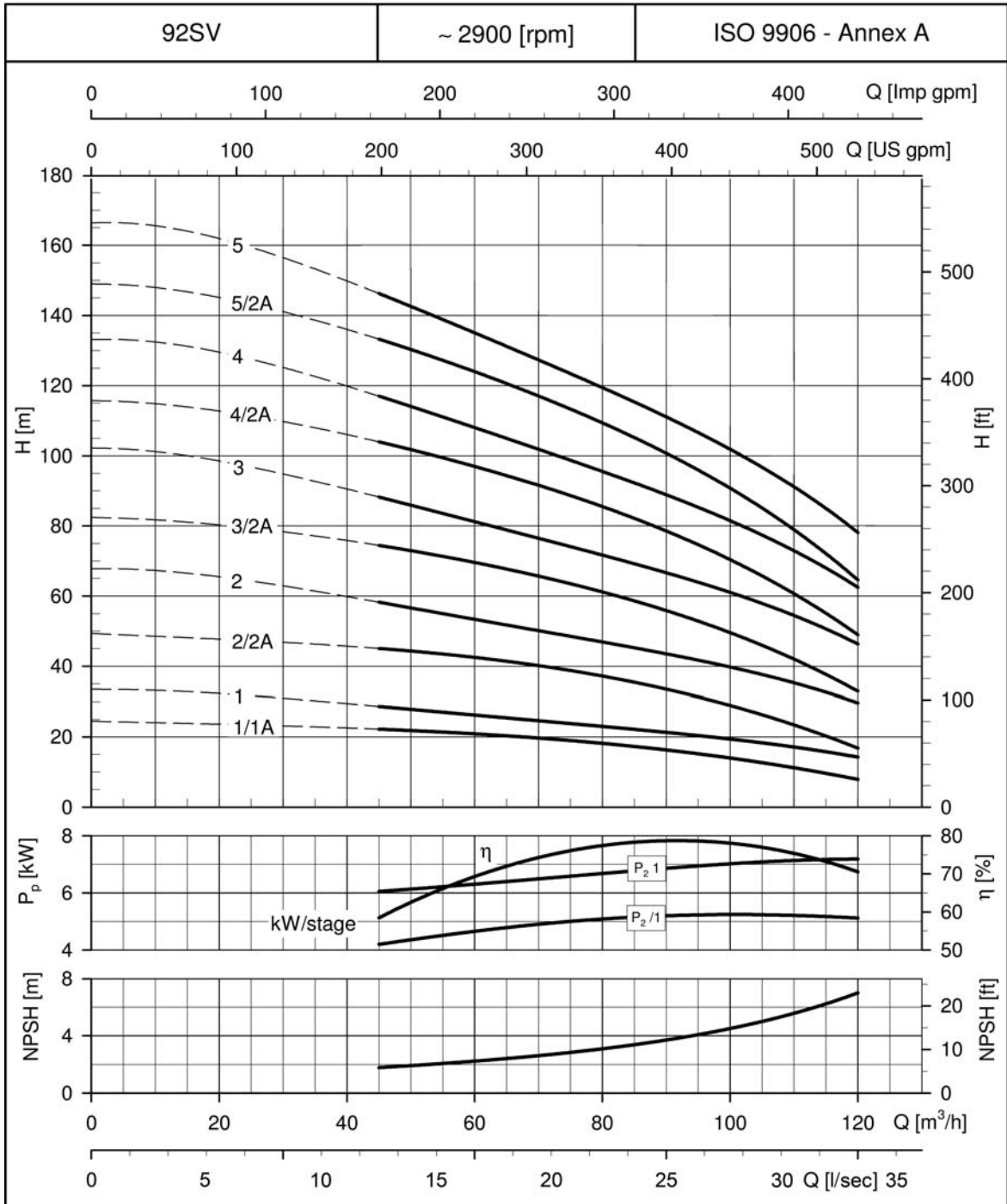

These performances are valid for liquids with density $\rho = 1.0 \text{ kg/dm}^3$ and kinematic viscosity $\nu = 1 \text{ mm}^2/\text{s}$.
 Booster Sets which are above 16bar pressure rating are available on request.
 Performance curves based on a single pump running, set losses are not included.

RESVARI RESIDENTIAL VARIABLE SPEED BOOSTER SET



- Integral water storage with Class AB air gap I.E. Category 5
- Duties up to 1 l/s.
- Head up to 4.2 Bar.
- Actual usable tank capacity 180 litres.
- Adjustable feet for easy levelling.
- Internal vessel for smooth pump control and minimising the number of pump starts.
- Input/output isolation valves for ease of maintenance and commissioning.
- Low water protection.
- Application, Domestic dwellings.

Boosted water supply

An ever increasing demand on our water supply lines can sometimes lead to poor performance at the point of use due to low pressures, especially at peak demand periods. In addition to this, water supply companies in some parts of the country are reducing pressures to avoid excessive water loss through leaks

A Lowara professionally sized and installed booster set will provide a perfect solution to overcoming low water pressures around the home.

Installing a Lowara booster set will ensure that water pressures for both hot and cold supplies will be able to cover the most demanding requirements.

The Resvari (variable speed) booster set will give energy savings over the life time of the pump and provide a very stable pressure platform irrespective of the number of outlets being used simultaneously.

Assist unit

Where a larger water storage volume is required a assist unit can be added to give an additional 180 litres of water storage.

Number of occupants	Maximum expected Flow	Maximum pressure	Minimum storage requirement	Standard booster set	Booster set + slave unit
1	0.4	4.2 bar	105lt	•	
2	0.5	4.0 bar	130lt	•	
3	0.6	3.8bar	150lt	•	
4	0.7	3.6 bar	200lt*	•	
5	0.8	3.2 bar	250lt		•
6	1	2.7 bar	300lt		•

POWER SUPPLY

230-1-50
 Protection IP65

PUMP TYPE

Scuba SC205C
 230-1-50
 Input current 4.37A

SYSTEM CONNECTIONS

Mains incoming water supply: 15mm
 Overflow: 22mm
 System connection: 22mm

MATERIALS

Cabinet: Powder coated steel
Water tank: Polyethylene
Ball valve 1/2": Brass to BS1212 part 2
Pump: SC205C AISI 304 Stainless steel
Pipework: Copper
Compression fittings: Brass
Isolation valves: Brass
Plastic fittings: Polypropylene
Tank insulation: Polyisocyanurate (PIR)
Anti-spin bracket: AISI 304 Stainless steel
8Litre Vessel: Powder coated steel with Butyl membrane

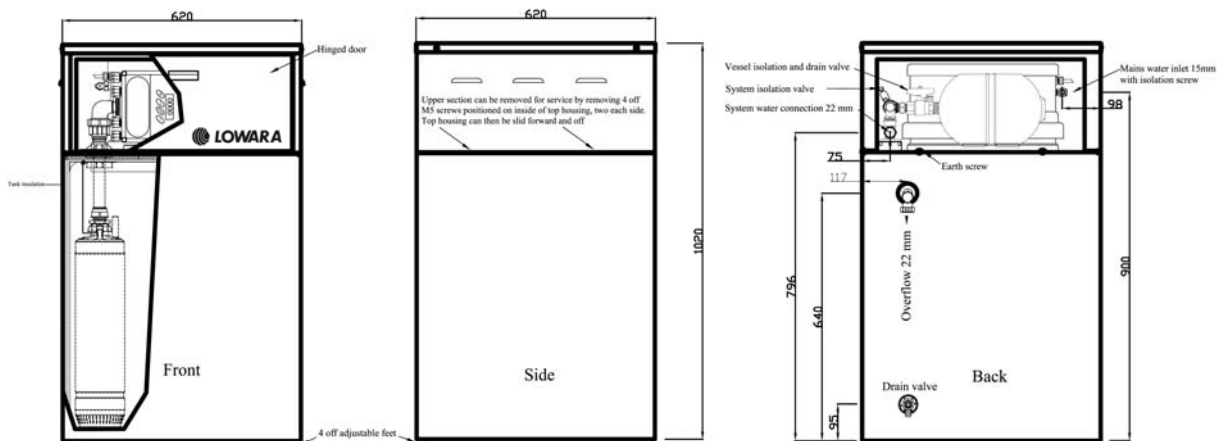

SCUBA SC205

OPERATING CHARACTERISTICS AT 50 Hz, 2 POLES

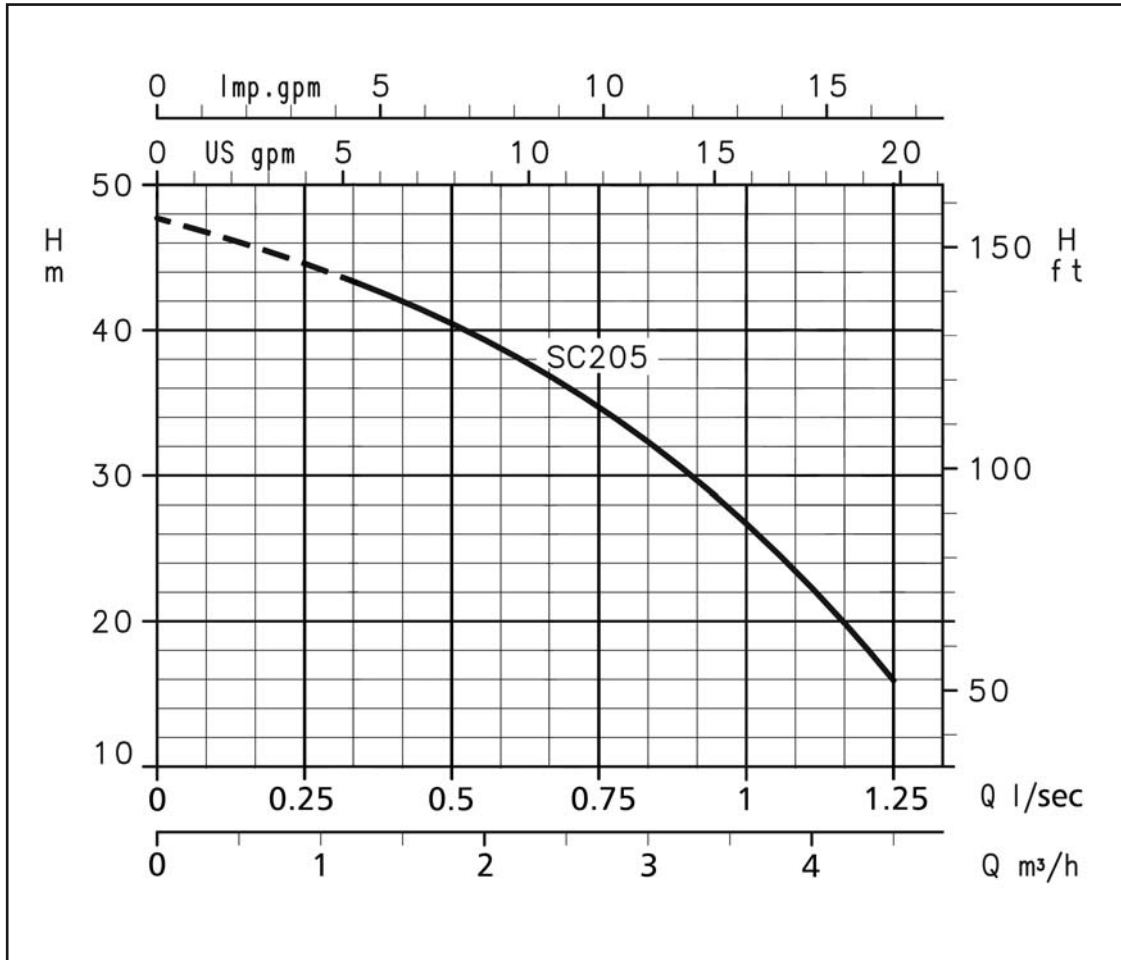

These performances are valid for liquids with density $\rho = 1.0 \text{ kg/dm}^3$ and kinematic viscosity $\nu = 1 \text{ mm}^2/\text{s}$.
 Performance curves based on a single pump running, set losses are not included.

MINI VH AND MINI VV VARIABLE SPEED BOOSTER SET

Lowara single and twin pump booster sets complete with pre-insulated integral break tanks suitable for boosting potable cold water. These sets can be fitted with either Teknospeed or Hydrovar energy saving variable speed drives.

All break tank sets include:

- Category 5 type AB air gap.
- Low water level float switch.
- 3/4" equilibrium ball valve and float (1/2" with 55 Litre tank).
- 1 1/2" overflow (3/4" with 55 Litre tank).
- 3/4" warning pipe on larger sets.
- Special booster sets and larger performance booster sets can be built to suit specific requirements.

HM/CA/CEA and e-SV versions available.

SPECIFICATIONS

Delivery: up to 12m³/h

Power supply: single-phase 50 Hz

Head: up to 5 bar

Power: from 0.03 kW to 2.2 kW

Optional: P.R.V.

Tank: 55 to 2000 Litre type A/B break tank

MATERIALS

Pump: Stainless steel

Tank: GRP

55 Litre tank Polyethylene

APPLICATIONS

- Domestic, commercial, industrial and building applications.

WATER STORAGE

Storing water has two main purposes,

1. To provide for an interruption in supply
2. to provide sufficient volume to cover peak demands.

Design codes recommend that storage is provided to cover the interruption of an incoming mains supply, in order to maintain a water supply to the building.

Water supply companies are empowered to insist on specific terms including the volume or period of storage, within the terms of their supply agreement with a consumer, however many water supply companies only recommend that storage be provided in accordance with BS6700, placing the responsibility and decision firmly on the consumer

Table 1 provides guidance on typical usage within a building over a 24 hour period.

Table 1 also provides storage volume based on the % of daily demand when the water supply company or client has not dictated the period of cover

Consideration should also be given to ensure that the break tank has sufficient volume to cover 50% of the design duty for a minimum duration of 10 minutes.

Mini VH version



Mini VV version



CONTROL PANEL AND BASIC CONNECTION DETAILS

Mini VH GTKS10 single phase booster set 1.1Kw

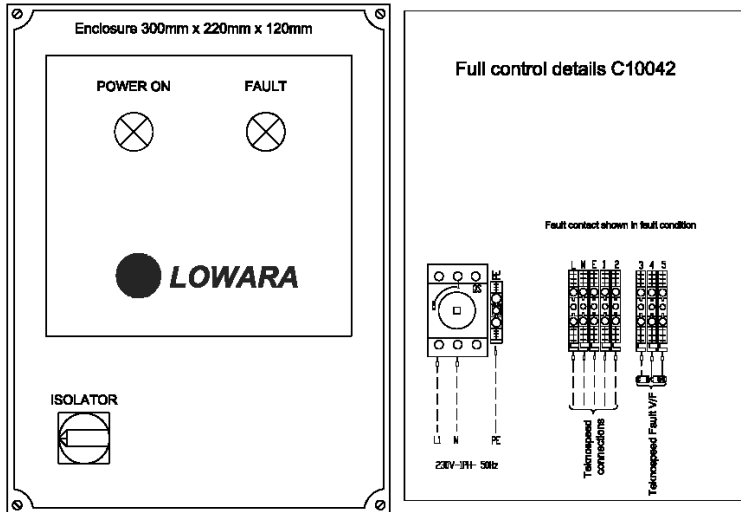

Mini VH GHV10 single phase booster set 1.5-2.2Kw

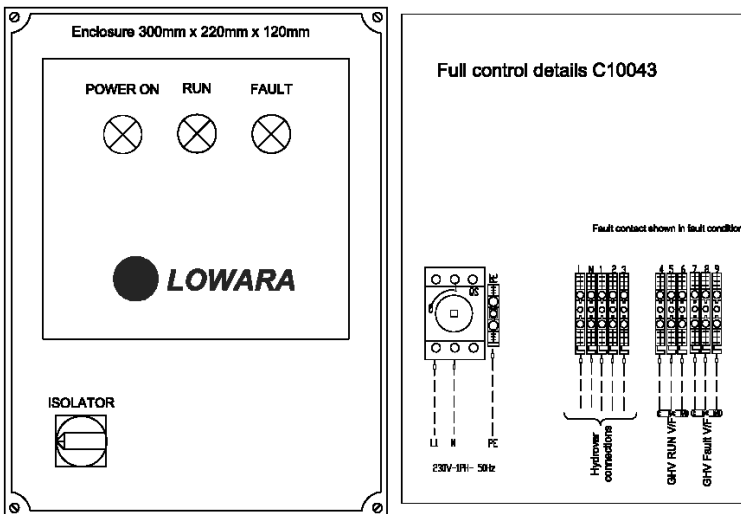

Mini VH GHV10 three phase booster set 2.2-4.0Kw

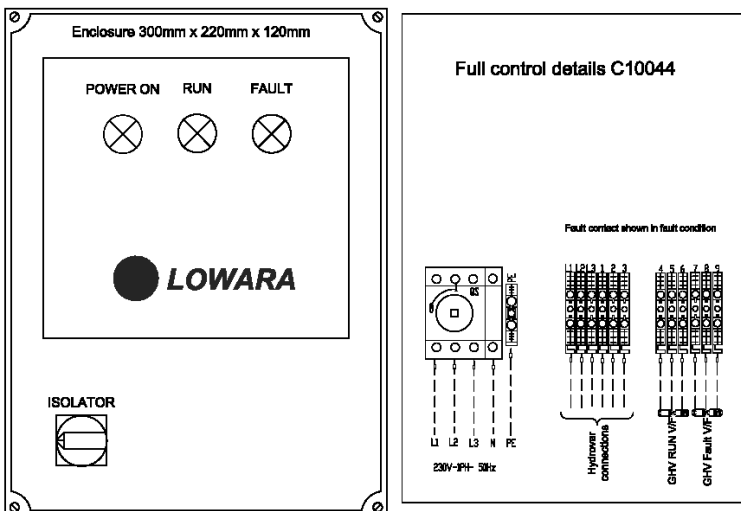

MINI VH AND MINI VV SERIES HYDRAULIC PERFORMANCE TABLE AT 50 Hz

PUMP TYPE	RATED POWER kW	Q + DELIVERY										
		l/min 0	20	30	40	50	60	70	80	100	120	
		m ³ /h 0	1.2	1.8	2.4	3	3.6	4.2	4.8	6	7.2	
H = TOTAL HEAD METRES COLUMN OF WATER												
TKS/2HM3ZT	0.3	22.2	20	18.2	16.1	13.7	10.9	7.9				
TKS/2HM5ZT	0.55	45.5	40	36.3	32.1	27.3	22.1	16.5				
TKS/2HM7ZT	0.75	57	50.8	46.2	40.8	34.6	27.8	20.5				
TKS/4HM4ZT	0.45	23.6			19.3	18.1	16.9	15.6	14.2	11.1	7.6	
TKS/4HM5ZT	0.55	35			28.6	26.9	25	23.1	21	16.6	11.5	
TKS/4HM9ZT	1.1	58.4			48.3	45.6	42.8	39.8	36.5	29.1	20.3	
TKS/4HMS7T	0.75	46.7			38.9	36.8	34.6	32.2	29.6	23.7	16.7	

PUMP TYPE	RATED POWER kW HP		Q = DELIVERY													
			l/min 0	12	20	25	30	35	40	45	50	60	73	100	120	141
			m ³ /h 0	0.7	1.2	1.5	1.8	2.1	2.4	2.7	3	3.6	4.4	6.0	7.2	8.5
H = TOTAL HEAD IN METRES OF COLUMN WATER																
3SV07F007T/UK	5.5	0.75	52.5		51.8	51.0	50.0	48.7	47.0	45.0	42.5	36.1	24.6			
3SV09F011T/UK	1.1	1.5	67.7		66.8	65.8	64.5	62.8	60.6	57.9	54.6	46.4	31.6			
3SV11F011T/UK	1.1	1.5	82.3		81.0	79.7	78.0	75.8	73.1	69.7	65.7	55.5	37.4			
5SV05F007T/UK	0.75	1	38.0						36.4	36.0	35.5	34.5	32.9	28.2	23.5	17.1
5SV08F011T/UK	11	1.5	60.1						57.6	57.0	56.2	54.6	51.8	44.1	36.2	25.8

PUMP TYPE	RATED POWER kW HP		Q = DELIVERY													
			l/min 0	83.34	100	133	170	183.34	233	270	330	350	400	430	460	483.33
			m ³ /h 0	5.0	6.0	8.0	10.2	11.0	14.0	16.2	19.8	21.0	24.0	25.8	27.6	29.0
H = TOTAL HEAD IN METRES OF COLUMN OF WATER																
10SV03F011T/UK	1.1	1.5	35.7	33.0	32.1	29.6	25.8	24.1	16.0							

Mini VH version

Mini VV version

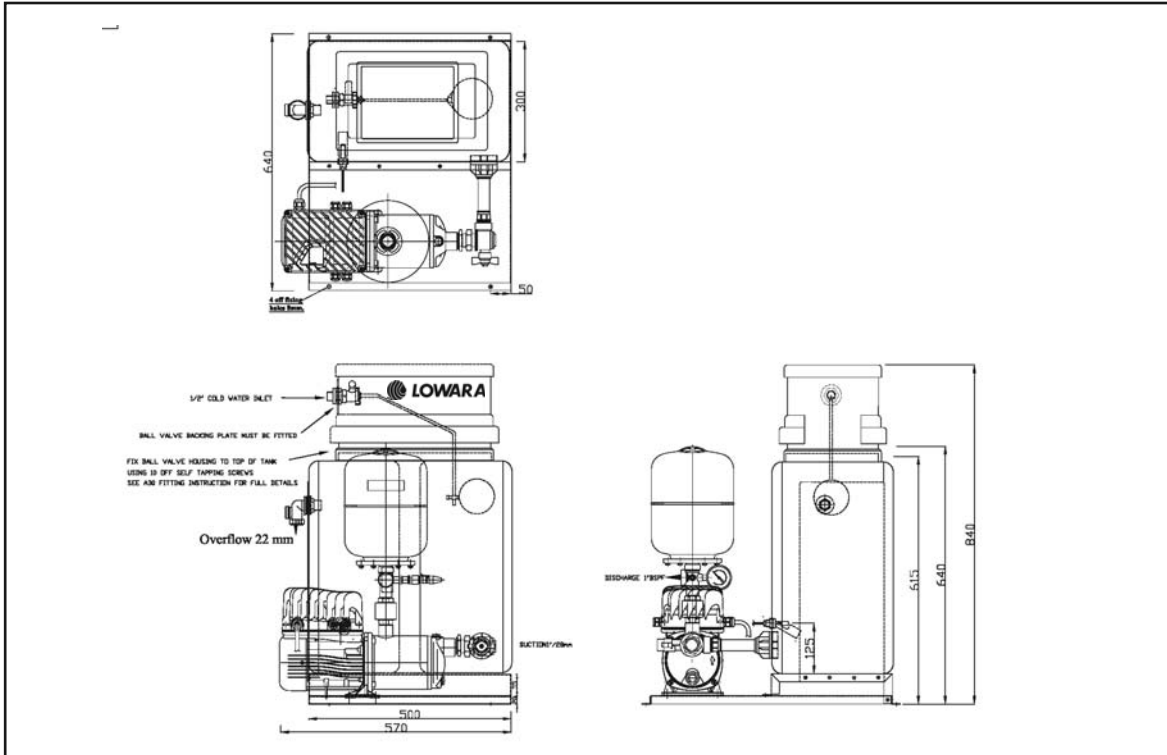

TKS2HM5-7 SERIES DIMENSION DETAILS

1 PUMP END SUCTION, WITH 55 LITRE BREAK TANK

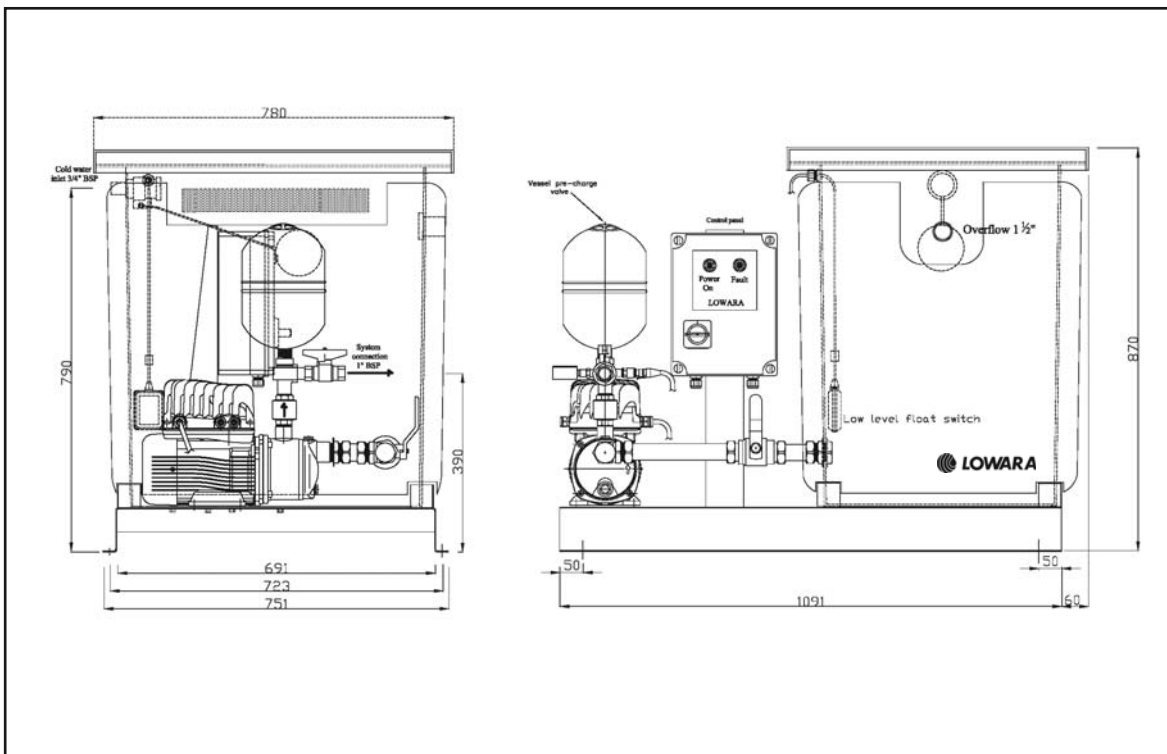

MINI VH SERIES DIMENSION DETAILS

1 PUMP END SUCTION, WITH 250 LITRE BREAK TANK



**GHV10/5SV F FLANGE DIMENSION DETAILS
1 PUMP MULTI STAGE, WITH 250 LITRE BREAK TANK**

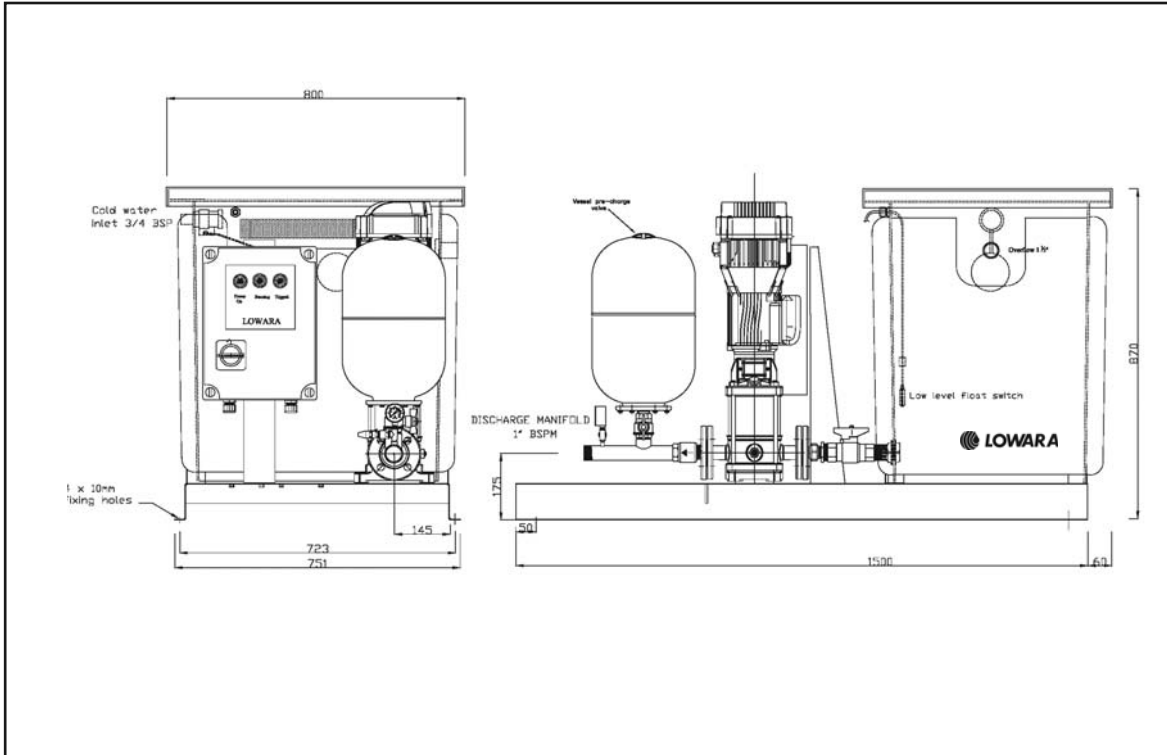

**GTKS20/HM SERIES DIMENSION DETAILS
2 PUMP END SUCTION, WITH 250 LITRE BREAK TANK**

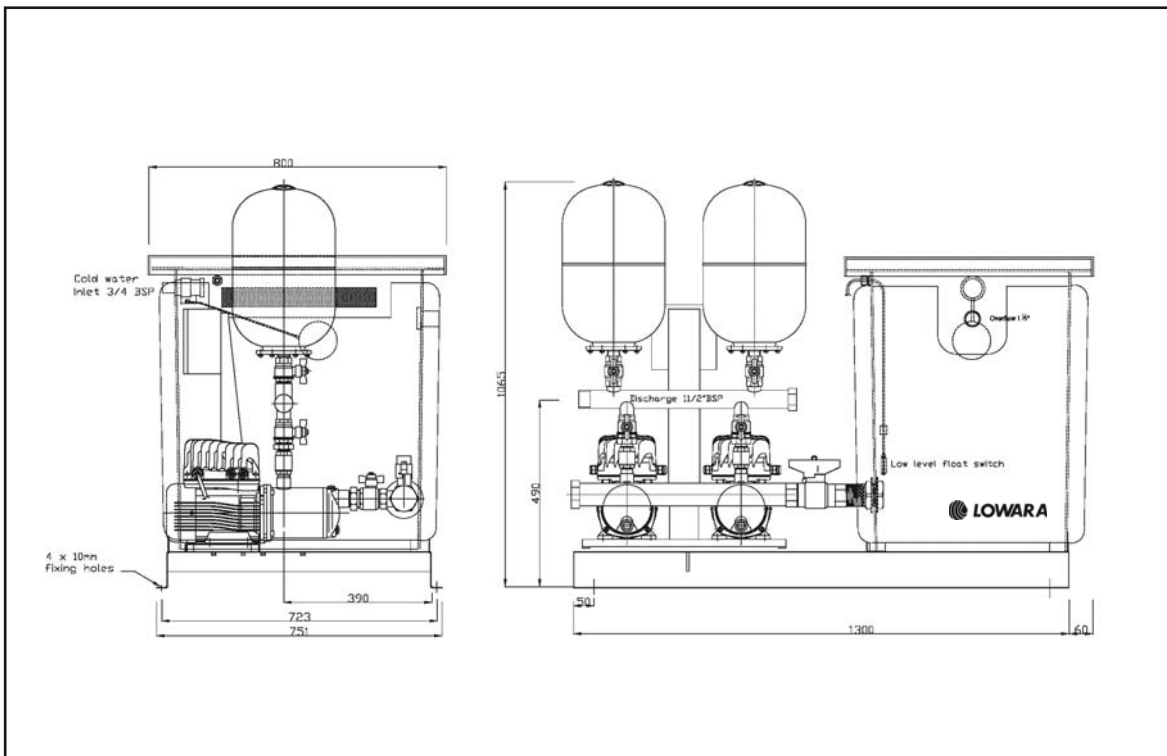

**GTKS20/3-5SV R FLANGE SERIES DIMENSION DETAILS
2 PUMP END SUCTION, WITH 250 LITRE BREAK TANK**

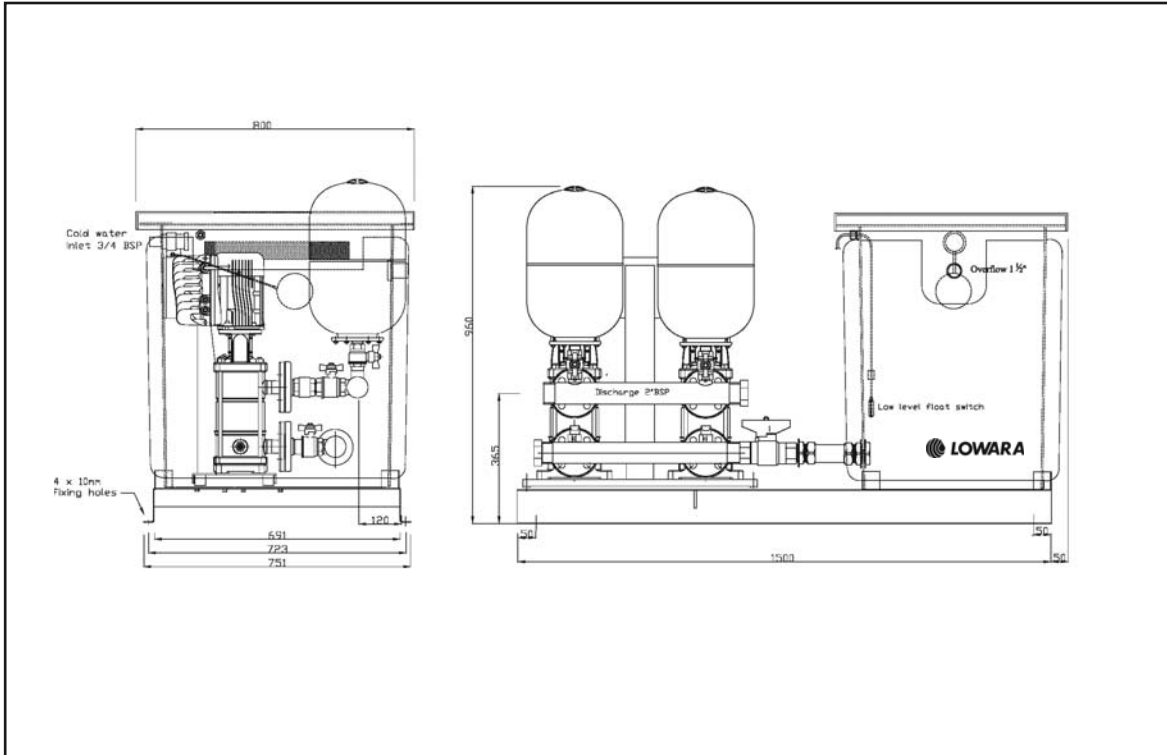

**GHV20/3SV 5SV 10SV SERIES DIMENSION DETAILS
GTKS 2 PUMP END SUCTION, WITH 250 LITRE BREAK TANK**

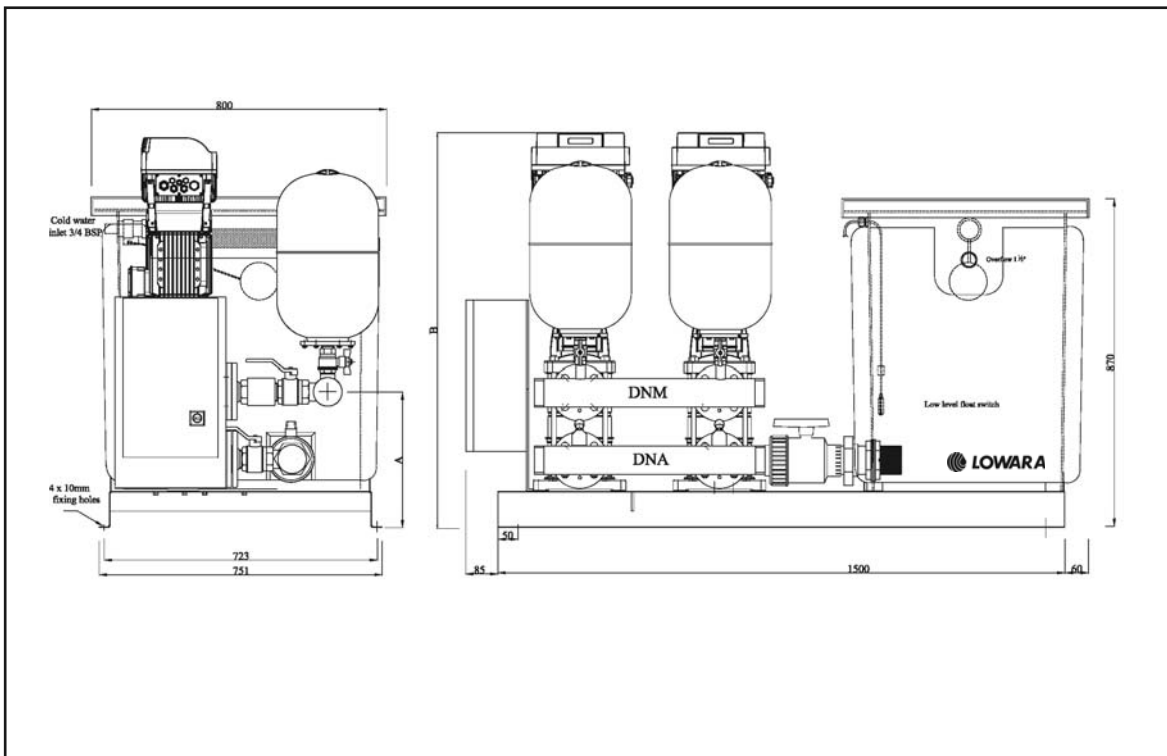

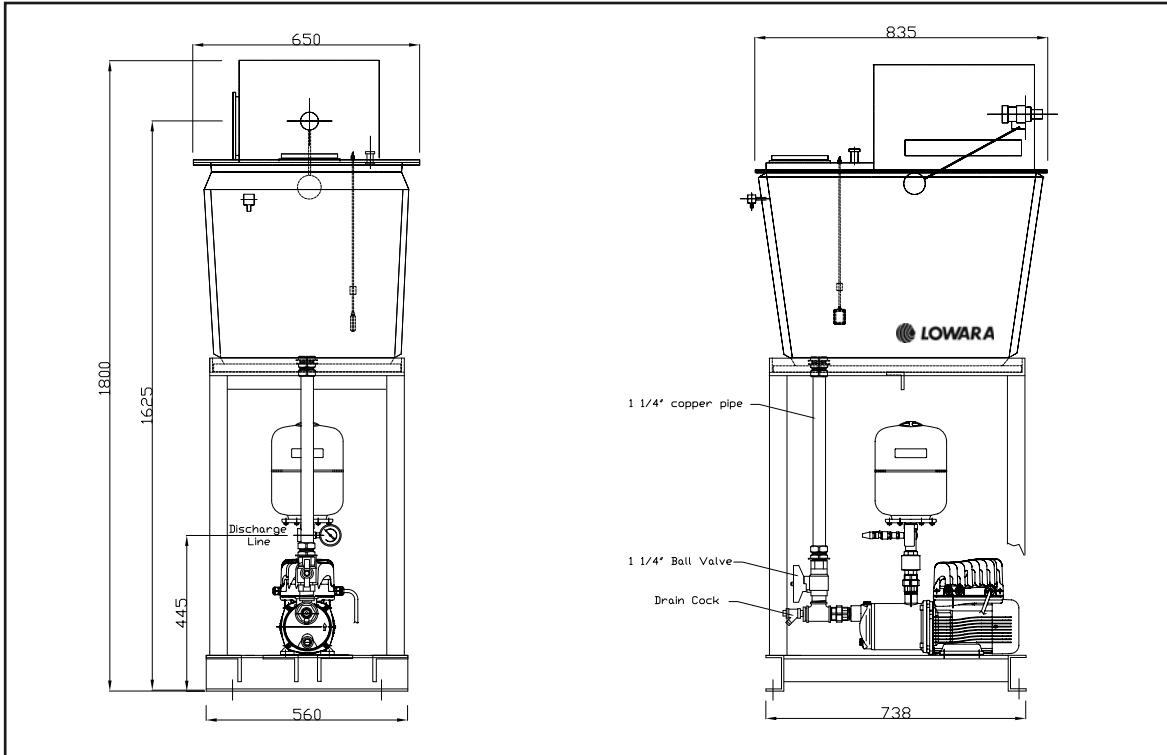
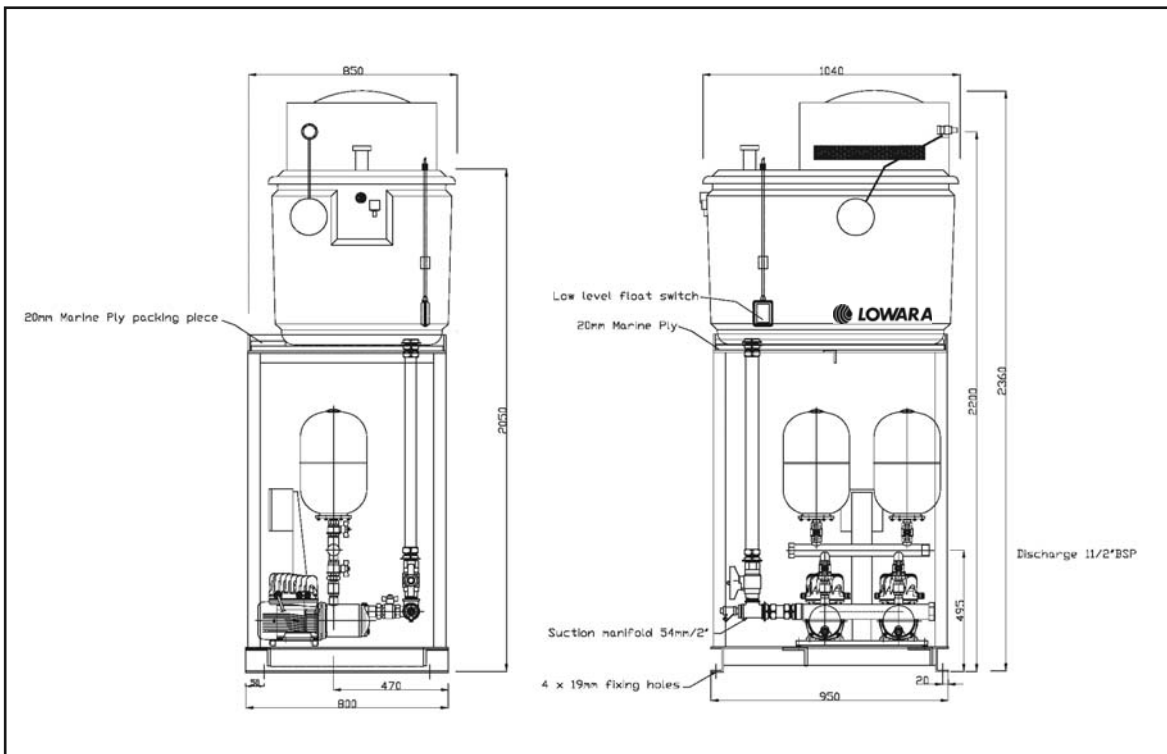
MINI VV SERIES DIMENSION DETAILS
TKS 1 PUMP END SUCTION, 230 LT BREAK TANK

GTKS20/4HM SERIES DIMENSION DETAILS
GTKS 2 PUMP END SUCTION, WITH 460 LITRE BREAK TANK

MINI VV SERIES DIMENSION DETAILS

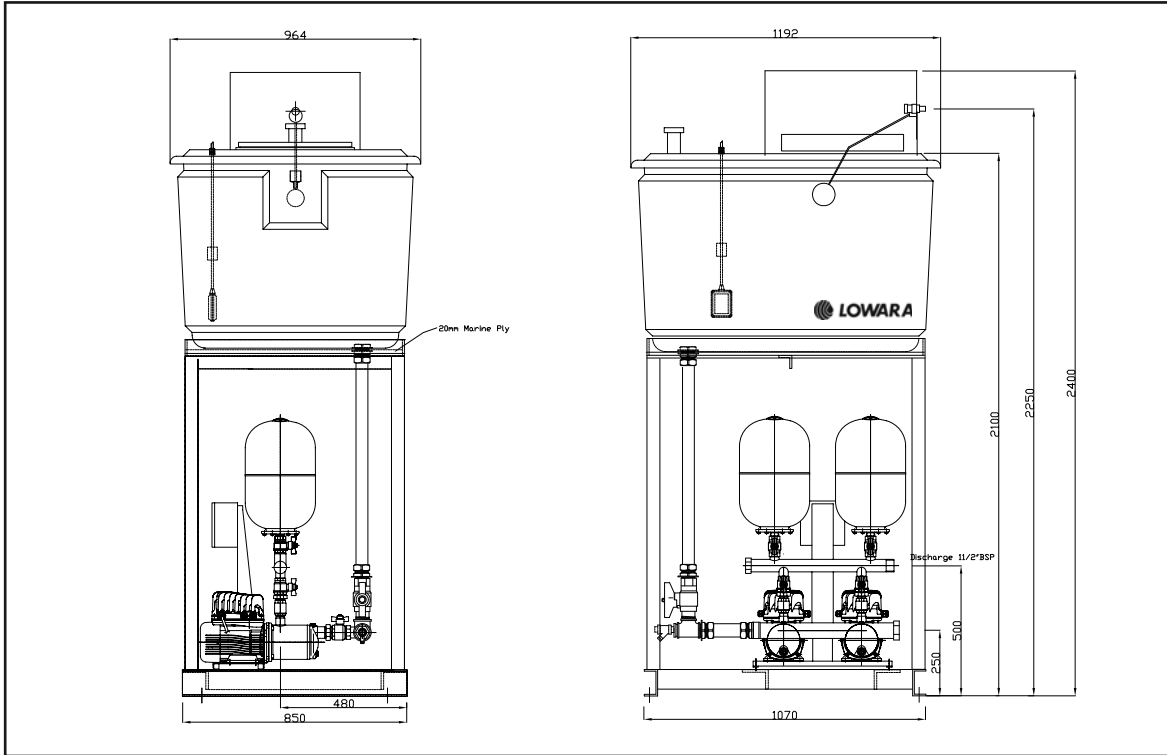
GTKS 2 PUMP END SUCTION, WITH 680 LITRE BREAK TANK

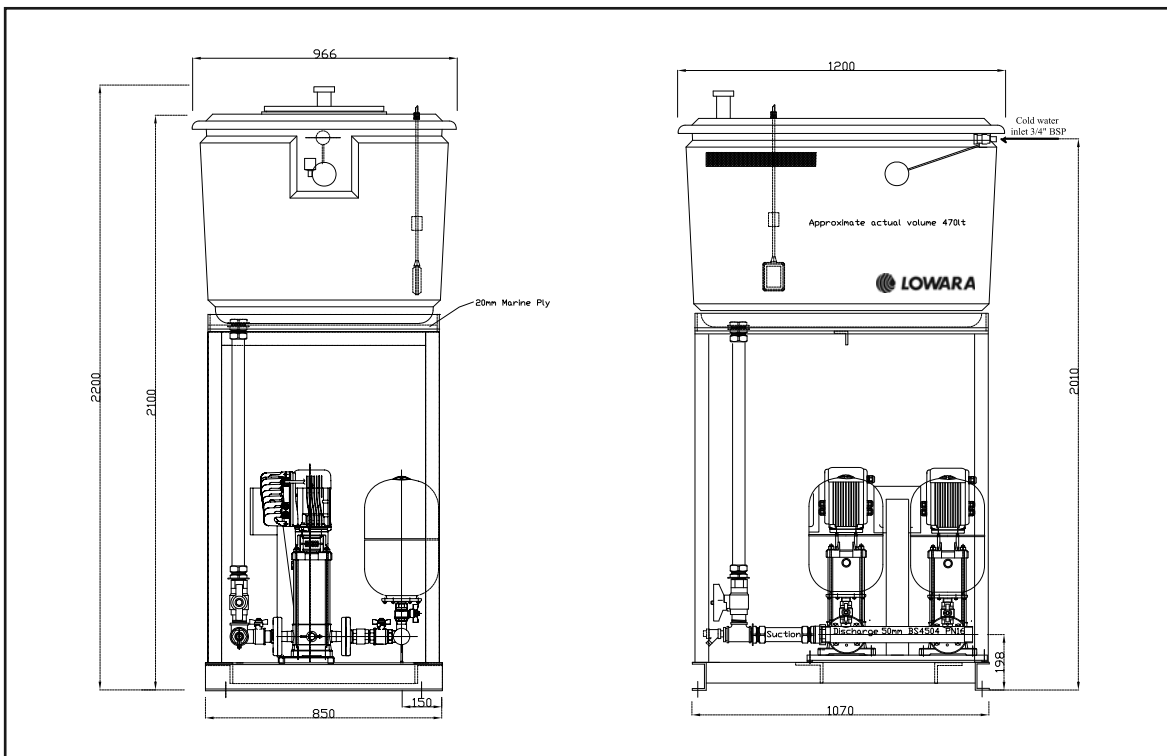

MINI VV SERIES DIMENSION DETAILS GTKS 2 PUMP MULTI-STAGE, WITH 680 LITRE BREAK TANK (WITHOUT BALL VALVE HOUSING)



MINI VV SERIES DIMENSION DETAILS GTKS 2 PUMP END SUCTION, WITH 1000 LITRE BREAK TANK

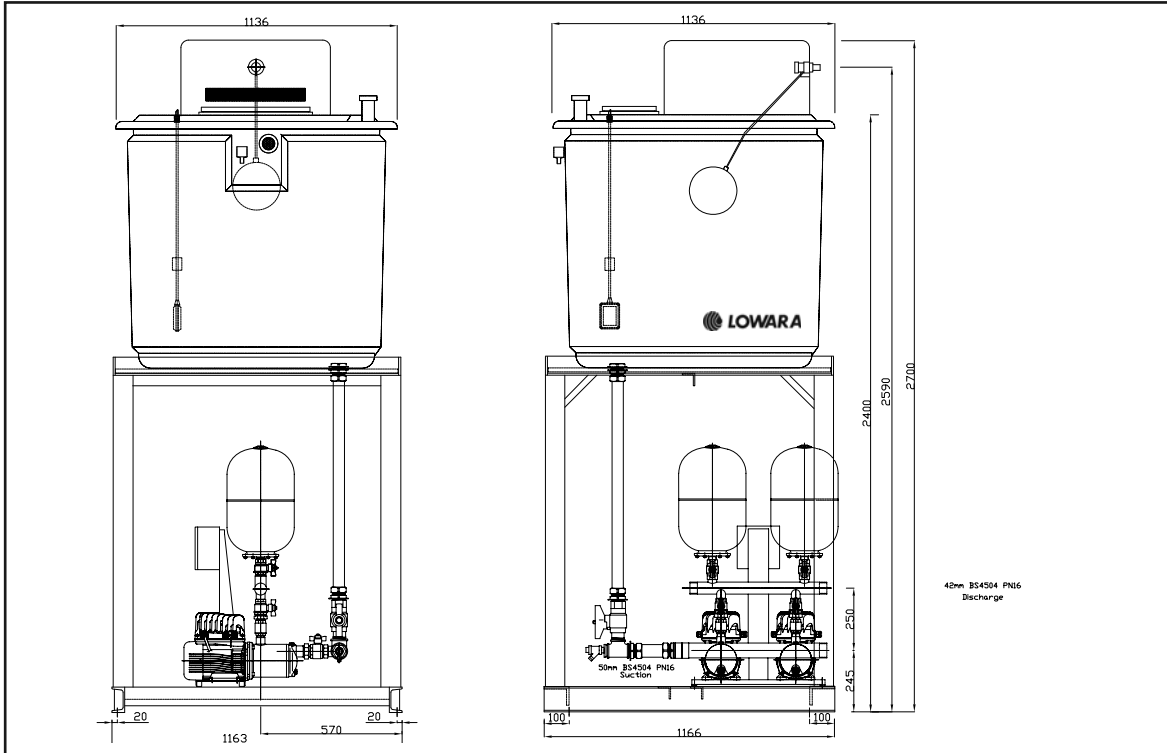

MINI VV SERIES DIMENSION DETAILS GHV 2 PUMP MULTI-STAGE, WITH 1370 LITRE BREAK TANK

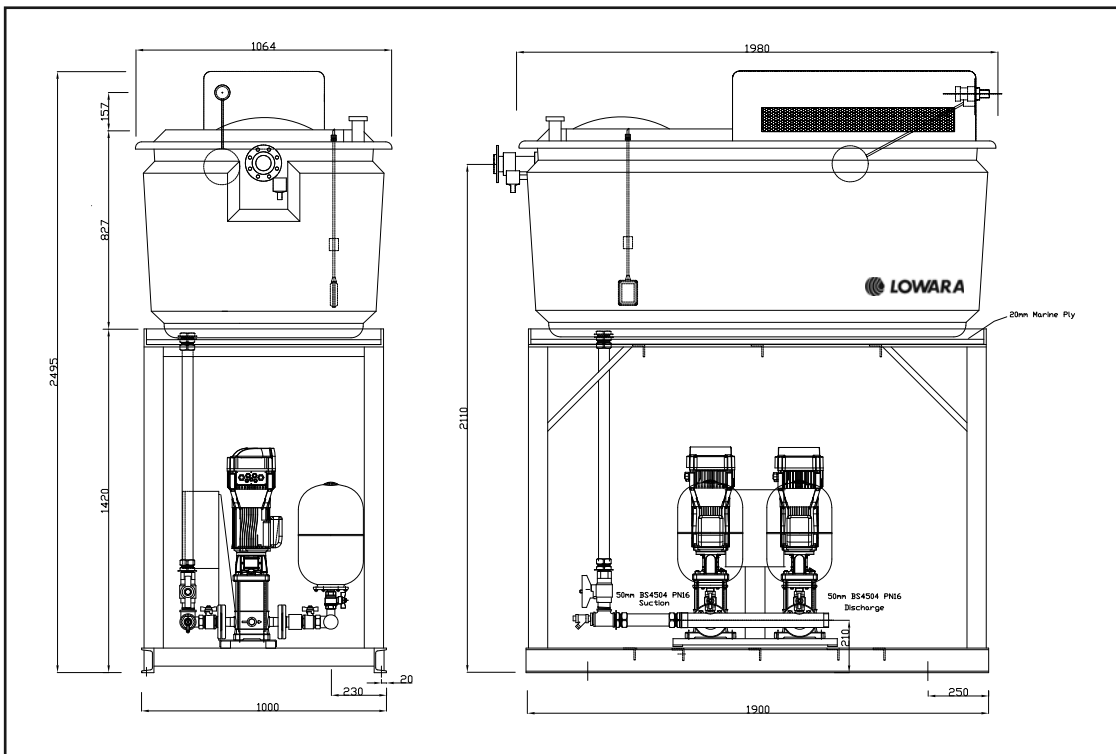

MINI VV SERIES DIMENSION DETAILS GTKS 2 PUMP MULTI-STAGE, WITH 1370 LITRE BREAK TANK

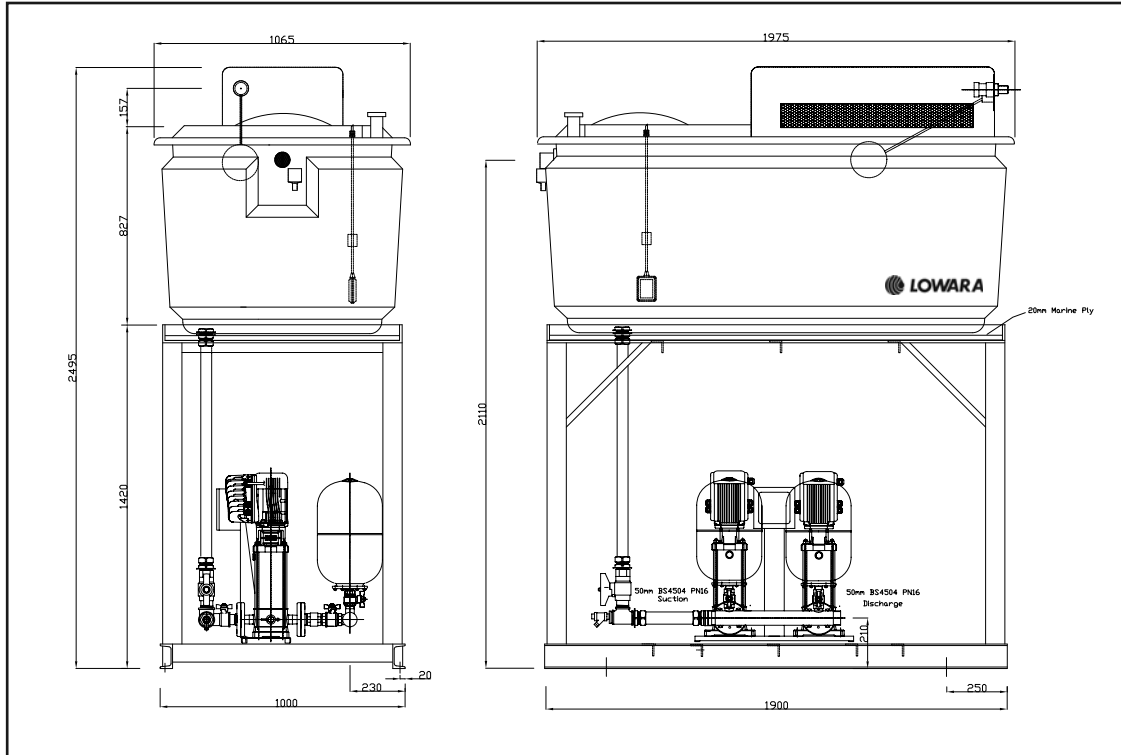

MINI VV SERIES DIMENSION DETAILS GHV 2 PUMP MULTI-STAGE, WITH 2000 LITRE BREAK TANK

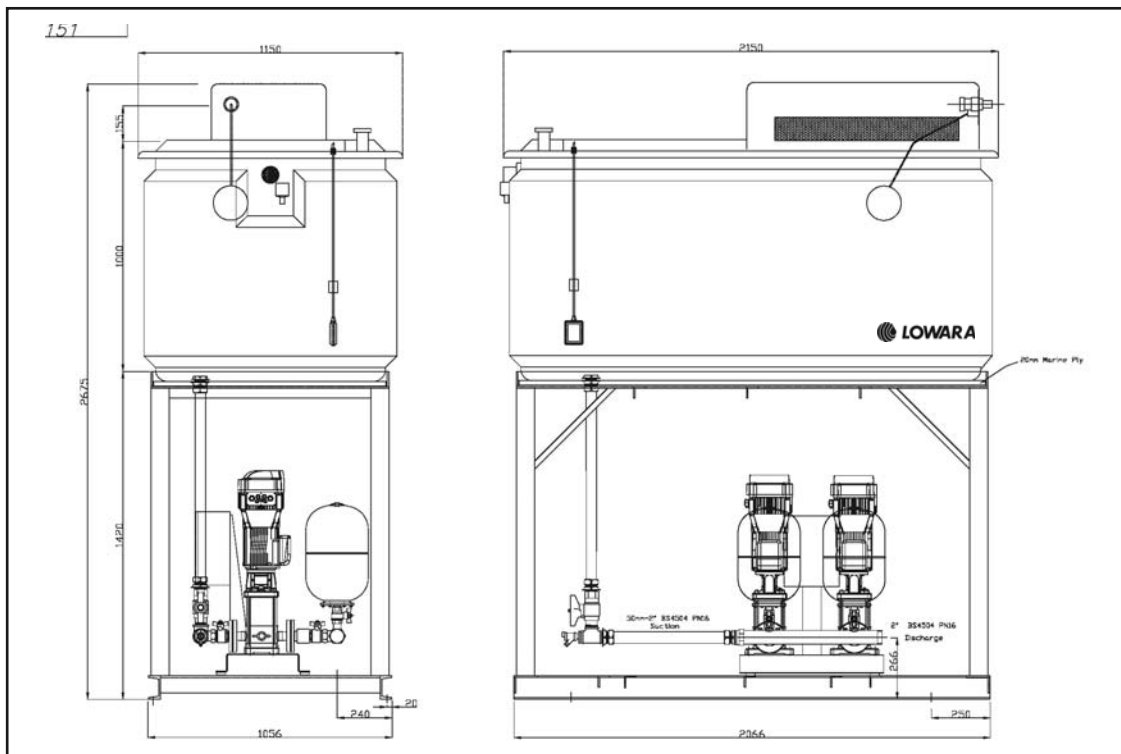



a xylem brand



LOWARA
a xylem brand



xylem
Let's Solve Water

About Xylem Applied Water Systems

Xylem's Applied Water Systems is known for its systems and applications expertise across the building services, general industrial, food and beverage, marine and agricultural markets. Serving the global marketplace with its leading portfolio of innovative and energy- efficient products and brands, AWS delivers on the challenge to solve the world's most critical water issues. For more information on AWS, please visit <http://www.xylemappliedwater.com>

Xylem

Xylem /'zīləm/

- 1) The tissue in plants that brings water upward from the roots.
- 2) A leading global water technology company.

We're 12,000 people unified in a common purpose: creating innovative solutions to meet our world's water needs. Developing new technologies that will improve the way water is used, conserved, and re-used in the future is central to our work. We move, treat, analyze, and return water to the environment, and we help people use water efficiently, in their homes, buildings, factories and farms.

In more than 150 countries, we have strong, long-standing relationships with customers who know us for our powerful combination of leading product brands and applications expertise, backed by a legacy of innovation. For more information on how Xylem can help you, please visit <http://www.xylem.com>



Lowara UK Limited

Millwey Rise Industrial Estate
Axminster, Devon EX13 5HU - UK
Tel: 01297 630230
Fax: 01297 630270
e-mail: lowaraukenquiries@xylem.com
<http://www.lowara.co.uk>
<http://www.xylem.com>

Xylem Water Solutions Ireland Limited

50 Broomhill Close
Airton Road
Tallaght - Dublin 24
Tel. (+353) 01 4524444
Fax (+353) 01 4524795
e-mail: lowara.ireland@xylem.com
<http://www.lowara.ie>

Lowara is a trademark of Xylem Inc. or one of its subsidiaries.
© 2011 Xylem, Inc.

Lowara reserve the right to make modifications without prior notice.

Code. UKLIT0057 P01/13

